



# Unit I- Vehicle Layouts, Front Axle and Steering Systems

By,  
Mr. A J Bhosale  
Asst. Professor  
Dept. of Automobile Engineering  
Govt. College of Engineering and Research, Avsari (Kd)



## Contents:

- 1) Course Objectives and Outcomes
- 2) Syllabus
- 3) List of Experiments
- 4) Reference Books
- 5) Marking Scheme



## ❖ *COURSE OBJECTIVES*

1. Understand types of vehicle layouts, front axle and steering systems.
2. Gain knowledge of suspension systems.
3. Describe the types of wheels, tyres and braking systems.
4. Acquire the basic knowledge of Clutches and Gearbox.
5. Explain the effect of drive ratio and differential.
6. Memorize the basics of automatic transmission.



## ❖ ***COURSE OUTCOMES***

**CO1. Classify** vehicle layouts according to different engine locations and **ILLUSTRATE** the working of front axle and steering systems.

**CO2. Define** key elements of suspension system

**CO3. Select** wheels, tyres for particular application and **RECITE** basics of braking systems.

**CO4. State** the significance of clutch and gearbox in automobile.

**CO5. Summarize** the working of final drive, differential and drive line components

**CO6. Evaluate** performance characteristics of fluid flywheel, torque converter and epicyclic gearbox and **AQUIRE** basic knowledge of CVT and Automatic Transmission.



## ❖ *Syllabus*

### ▪ *Unit – I Vehicle Layouts, Front Axle and Steering Systems*

Introduction, Classification of automobile, Types of chassis layout with reference to power plant locations and type of drive, Types of chassis- fully forward, semi forward, Truck or bus chassis, two & three wheeler chassis layout.

Functions of front axle, Types of front axle, Construction, Stub axle and Wheel bearing, Front wheel steering Geometry – castor, Camber, King pin inclination, toe-in, toe-out, Centre point Steering, Self returning property, Adjusting and checking of front wheel geometry, Ackerman and Davis steering linkages, Steering system layout, Steering gear boxes. (07 hrs.)



## *Unit – II Vehicle Suspension Systems*

Road irregularities and need of suspension system, Types of suspension system, Sprung and unsprung mass, Suspension springs – requirements, types and characteristics of leaf spring, coils spring, rubber spring, air and torsion bar springs, Independent suspension for front and rear, Types, Hydro-elastic suspension, Roll centre, Use of anti-roll bar and stabilizer bar, Shock absorbers – need, operating principles and types, Active suspension. (07 hrs.)



## ***Unit – III Wheels, Tyres and Braking Systems***

Basic requirements of wheels and tyres, Types of road wheels, Construction of wheel assembly, wheel balancing, Tyre construction, material, types, tubeless, cross ply radial type, tyre sizes and designation, Aspect ratio, tyre trade pattern, tyre valve, Tyre inflation pressure, safety precautions in tyres, Tyre rotation and matching, Types of Tyre wear and their causes, Selection of tyres under different applications, tyre retreading hot and cold, factors affecting tyre performance. Function and requirements of braking system, Types of brakes, Elementary theory of shoe brake, drum brake arrangement, disc brake arrangement, self-energizing, brake friction material. brake linkages, hydraulic brake system and components, hydraulic brake fluids, air brakes, vacuum servo assisted brake, engine exhaust brake, parking brakes, dual power brake system, regenerative brake system, fail-safe brake, anti – lock brakes, anti-skid brakes, brake efficiency and testing, weight transfer, braking ratio. (08 hrs.)



## ■ *Unit – IV Clutches & Gear Box*

**Clutches:** Principle, Functions, General requirements, Torque capacity, Types of clutches, Cone clutch, Single-plate clutch, Diaphragm spring clutch, Multi-plate clutch, Centrifugal clutch, Electromagnetic clutch, Lining materials, Over-running clutch, Clutch control systems.

**Gear Box:** Necessity of gear box, Resistance to motion of vehicle, Requirements of gear box, Functions of gear box, Types, Sliding mesh, Constant mesh, Synchromesh. Principle, construction and working of synchronizing unit, Requirements & applications of helical gears, Gear selector mechanism, Two wheeler gear box, Lubrication of gear box, Overdrive gears, Performance characteristics.

(08 hrs.)





## ▪ *Unit – V Drive Lines, Final Drive & Rear Axle*

Effect of driving thrust and torque reaction, propeller shaft-universal joints, hooks and constant velocity U.J., Drive line arrangements – Hotchkiss drive & torque tube drive, Rear wheel drive & front wheel drive layouts .

Purpose of final drive & drive ratio, Different types of final drives, need of differential, Constructional details of differential unit, Non-slip differential, Differential lock, Differential housing, Function of rear axle, Construction, Types of loads acting on rear axle, Axle types - semi-floating, full floating, three quarter floating, Axle shafts, Final drive lubrication. (07 hrs.)



## ■ *Unit – V Automatic Transmission*

Fluid Flywheel, Torque convertor: Operating principle, Construction and working of fluid flywheel, Characteristics, Advantages & limitations of fluid coupling, Torque convertor, and construction and working of torque converter, Performance characteristics, Comparison with conventional gear box.

Epicyclic Gear Boxes: Simple epicyclic gear train, Gear ratios, Simple & compound planet epicyclic gearing, Epicyclic gearboxes, Wilson epicyclic gear train - Construction and operation, Advantages, Clutches and brakes in epicyclic gear train, compensation for wear, performance characteristics.

Principle of semi automatic & automatic transmission, Hydramatic transmission, Fully automatic transmission, Semi automatic transmission, Hydraulic control system, Continuous variable transmission (CVT) – operating principle, basic layout and operation, Advantages and disadvantages. (08 hrs.)



❖ **List of Experiments:** (Any 8 Experiments from Experiments No. 1 to 10. Experiment No.11 is Compulsory)

1. To Study different vehicle layouts.
2. Demonstration of steering, suspension & braking system used in automobiles.
3. Adjustments, overhauling, and repair of Two Wheeler Clutch
4. Adjustments, overhauling, and repair of Four Wheeler Clutch (Light / Heavy Duty Vehicle).
5. Adjustments, overhauling, and repair Constant Mesh Gearbox and Synchromesh Gearbox.
6. Adjustments, overhauling, and repair of Drive Line (Universal Joint, Propeller Shaft, Slip Joint).
7. Adjustments, overhauling, and repair of Final Drive & Differential.
8. Demonstration and study different types of Front and Rear Axles.
9. To study Fluid Flywheel and Torque Converter.
10. To study Continuous Variable Transmission (CVT).
11. Any One Visit from Below
  - a) Visit to Vehicle Service Station to Study Power Transmission of Vehicle
  - b) Visit to any Automotive Industry for Vehicle Transmission / Assembly Line.



❖ **Text Books:**

1. Dr. Kripal Singh, “Automobile Engineering-Vol. 1”, 13th Edition, Standard Publishers Distributors.
2. N. K. Giri, “Automotive Mechanics”, Khanna Publishers, Delhi, Eighth Edition
3. C. P. Nakra ,“Basic Automobile Engineering”, Dhanpat Rai Publishing Company (Pvt) Ltd.

❖ **Reference Books:**

1. Bosch “Automotive Handbook”, Robert Bosch GmbH, Germany.
2. W. H. Crouse and D. L. Anglin ,“Motor Vehicle Inspection”,
3. Ramlingam , “Automobile Engineering” (Anna University )
4. Josepf Heitner , “Automotive Mechanics”.
5. J.G .Giles “Vehicle Operation and Performance”.
6. George Pieters, Barbara Pieters, “Automotive Vehicle Safety”.
7. Jousha H. M, “Engine performance Diagnosis and Tune up Shop Manual”.
8. Newton, Steed & Garrot, “Motor Vehicles”, 13th Edition, Butterworth London
9. W. Judge, “Modern Transmission”, Chapman & Hall Std., 1989,
10. Chek Chart, “Automatic Transmission”, A Harper & Raw Publications,
11. Heisler, “Vehicle and Engine Technology”, Second Edition, SAE International Publication.



# Marking Scheme

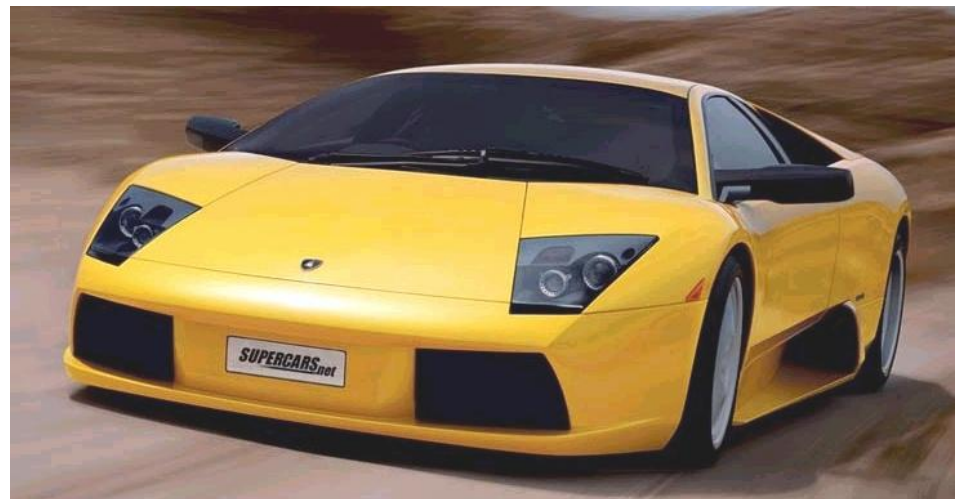
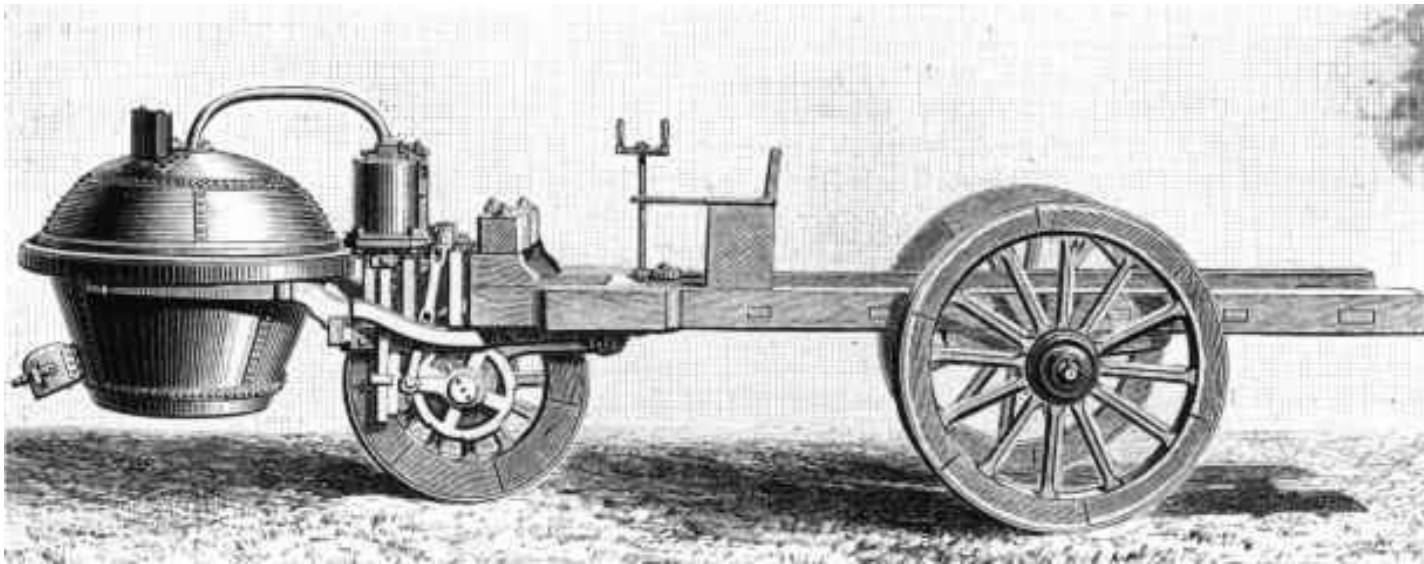
## 316486: Automotive Chassis and Transmission

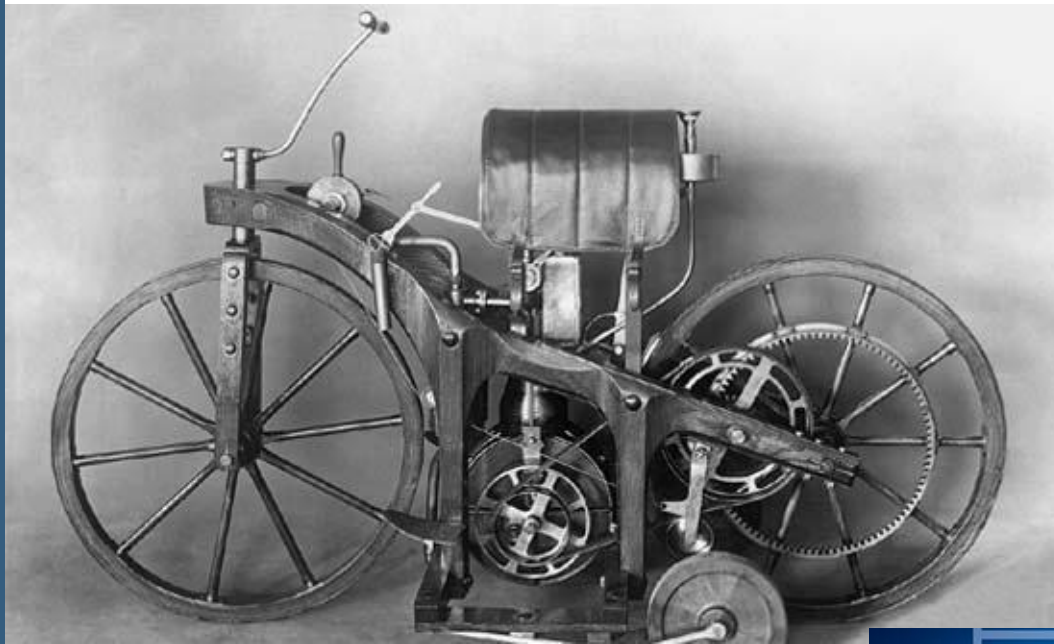
Teaching Scheme		Credits		Examination Scheme	
Theory	03 Hr./Week	Theory	03	In-Semester	30 Marks
Practical	02 Hr./Week	Practical	01	End-Semester	70 Marks
				Practical	50 Marks



## ❖ Introduction:

- The automobile as we know, it was not invented in a single day by a single inventor. The history of the automobile reflects an evolution that took place worldwide.
- It is estimated that over 100,000 patents created the modern automobile.









## History

Automobiles through the Years

Since originated on late 1800s,  
developed and modified in response to

- Customer's requirements
- Economic Conditions, and
- Advancing Technology.

Current designs continue to latest technology, although many different markets exists.

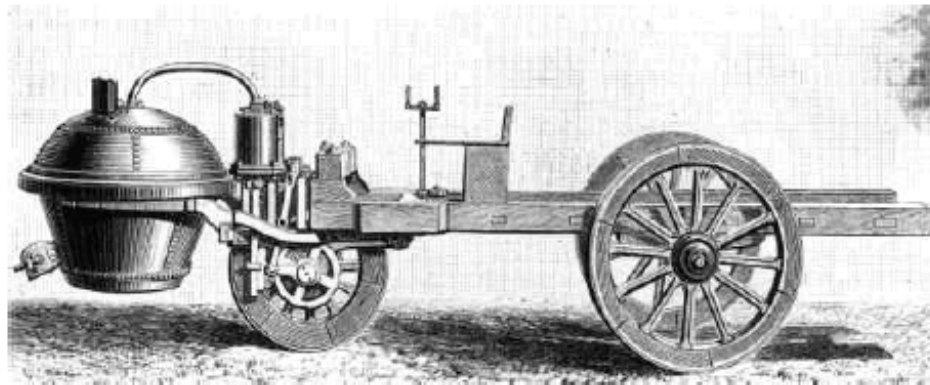


## History...

- 4,000 Years ago  
Used for Transportation in India
- 15<sup>th</sup> Century  
Portuguese & Chinese created Wheel that turned under its own power
- 1600  
Small Steam-Powered Engine models developed

## Cugnot Steam Tractor

- 1769-First Automobile-By Nicolas Cugnot  
Three-wheeled steam-powered vehicle  
Speed  $\approx$  3.2 km/h (2mph)  
Had to stop every 20min  
to build up fresh head of steam





## Few Records

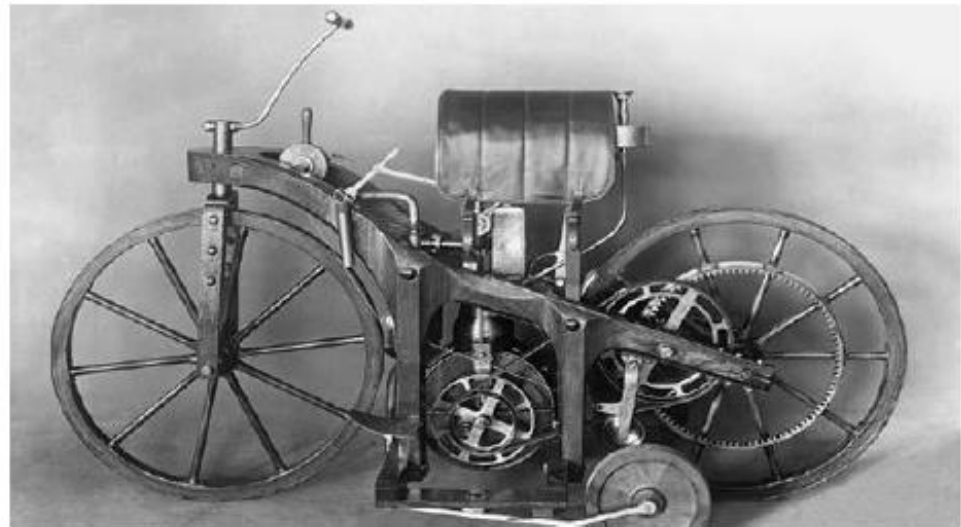
- 1801 Heavy steam automobiles introduced in England
- 1802 Steam powered coach journeyed 160km (100mi)
- Mid 1800-England-extensive network of steam coach lines
- 1830 Steam carriages used for first omni bus service in London
- 1906 Stanley steamer established world land speed record  
205.44km/h(121.573mph)



## Internal - Combustion Engine

- 1860 One-cylinder engine, kerosene- fuel.
- 1864 Two-cylinder gasoline engine
- 1876 Otto built four-stroke gas engine 2-stroke engines accomplish the same steps, but less efficiently & with more exhaust emissions.
- 1885 Gasoline-powered engine mounted onto bicycle-motorcycle &
- 1887 First car- included steering tiller & 4-speed gearbox - Daimler & Maybach

- In 1885 German engineer Gottlieb Daimler mounted an engine of his own design into a wood-framed vehicle.
- The vehicle had 4 wheels, including 2 round stabilizing wheels.
- World's first motorcycle.



## Early Car

- 1885 First practical car (gasoline car)

– By Karl Benz

Incorporating differential drive & other components





## Design Improvements

- 1891 Peugeot automobile paced 1,046-km (650-mi)
- 1894 Instead of installing engine under seats, front-mounted engine under hood along with clutch, gears, & separate construction of the chassis designed
- 1899 Fiat in Italy – began building cars



## Horseless Carriage

- 1893
  - By Duryea brothers -Original Horseless Carriage - -America's First Internal Combustion Motor Car
  - Henry Ford built IC Engine
- 1896- Henry Ford used engine power on bicycle steered by tiller





## Early Electric Cars

- 1800s Electric engines (quiet, slow speed & not scaring to horse & people), enjoyed great popularity
- 1899 Electric car designed & driven to set a record of 105.8810 km/h (65.79 mph)
- Most electric cars-top speed 48km/h (30mph), could go only 80km (50mi) before recharging



## 20<sup>th</sup> Century

- For many years commonly used power sources - steam engines, gasoline engines and electric motors.
- Gasoline powered engines became universal choice to have – longer trips & faster speeds
- 1902 First American car (Locomobile)  
had 4-cylinder, water cooled, front mounted gasoline engine – very similar in design to most cars today



## Shaping Up!

- 1906 Gasoline powered cars had
  - a hood covered front mounted engine
  - two kerosene/acetylene lamps (head lights)
  - fenders covering wheels & step up platforms
  - passenger compartment-behind engine
- 1911 Electric self starter introduced to replace hand crank to start engine  
Electric head lights introduced



## Ford

- 1903 First automobile – Ford Model A each year new Ford models B, C...
- 1908-1927 – 15 million cars of **Model T**

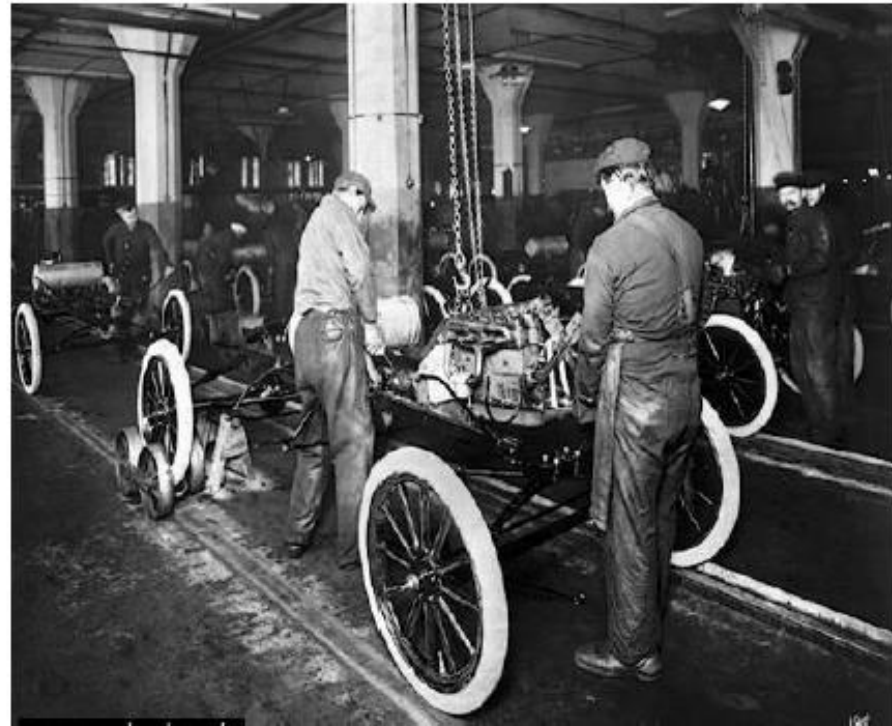
adopting innovative  
**assembly line**  
method

Affordable for an  
average wage earner!



## Assembly of a Model T

Two workers mount an engine into the chassis of a Ford Model T that was put together at earlier points on the assembly line.



# Luxury Automobiles

(For comfort & style rather than speed)

- 1909 Rolls-Royce Silver Ghost -quiet 6-cylinder engine, leather interior, folding windscreens & aluminum body.





# Design Improvements

- 1920 Synchronesh Transmission (for easy gear shifting), improved carburetors, shatterproof glass, heaters, balloon tires, 4 - wheel hydraulic brake systems, pressed-steel wheels, and mechanically operated wind shield wipers incorporated



## Vintage Models

Made to individual specifications

- 1929 – Graham Paige DC Phaeton  
8-cylinder engine & aluminum body





## Improvements

- 1930 -1937

Large Engines (12-16 cylinder) &  
**large -luxurious** Bodies

Independent front suspension, (made big cars more comfortable )

more reliable braking systems,

higher-compression engines (for more hp)

- **1936 - Mercedes introduced World's first Diesel Car**

# Convenient, Reliable & Inexpensive

- 1937 Pontiac De Luxe Sedan  
roomy interior rear hinged back  
door  
suited to the needs of families



## Car For The People

- 1949 A combination of look and economy that remained popular for more than four decades.

VW Beetle



# Car For The People



## Volkswagen "Beetle"

With a rear-mounted engine and rounded, bug like shape, appealed to buyers seeking utilitarian good looks, easy serviceability, and fuel efficiency. The classic Beetle became the best-selling car of all time, with more than 21 million sold.



## VW New Beetle

In early 1998 Volkswagen put the first "New Beetle" on the American market

## Muscle Car

- 1964 - **Mustang** Ford's best early sales success since introduction of Model T.

popular characteristics

- ↗ small, fast design,
- ↗ excellent handling,
- ↗ powerful engine &
- ↗ distinctive look.





## ❖ Classification of Automobiles

1. Capacity (HMTV ,LMV)
2. Power ( Petrol, Diesel, Gas, Electric)
3. Use (Cars ,Buses ,Trucks ,Motor Cycles )
4. Wheels (2.3.4.6 ....)
5. Make ( Bajaj, Vespa, Hero, Honda, Maruti)
6. Drive (LHD, RHD)
7. Transmission ( Conventional, Automatic)
8. Purpose (Passenger,Goods)



## ❖ Chassis:

- Chassis is a French term which denotes the whole vehicle except body in case of heavy vehicles.
- In case of light vehicles of mono construction it denotes the whole body except additional fitting in the body.
- Chassis consists of engine, brakes, steering system & wheel mounted on the frame, differential, suspension.
- Propel and control a automobile.





## ❖ ITS PRINCIPAL FUNCTION:

- To safely carry the maximum load.
- Holding all components together while driving.
- Accommodate twisting on even road surface.
- Endure shock loading.
- It must absorb engine & driveline torque.



## ❖ CLASSIFICATION OF CHASSIS

According to control:

- Conventional-forward chassis
- Semi-forward chassis
- Full-forward chassis

## ❖ Conventional chassis:

- Engine is fitted in front of the driver cabin or driver seat such as in cars.
- Chassi portion can not be utilized for carrying passengers and goods





## Explain the **Automobile Chassis**?

Automobile Chassis

Conventional Chassis

### Keywords

- ▶ *Internal Framework*
- ▶ *Frame Supporting the Vehicle*
- ▶ *Major Units*
- ▶ *Propelling and Controlling*



**AUTOMOBILE CHASSIS** is defined as the *Internal Framework* which consists of a *Frame Supporting the Vehicle* and all the *Major Units* responsible for *Propelling and Controlling* of the Vehicle.

## ❖ Semi-forward chassis

- Half portion of the engine is in the driver cabin and remaining half is outside the cabin such as in Tata trucks
- In this arrangement a part of the chassis is utilized for carrying extra passengers





## Explain the **Automobile Chassis**?

### Automobile Chassis

#### Semi-forward Chassis

- ▶ Half Engine fitted inside Driver's Cabin and Remaining half in the front of Driver's Cabin

### Keywords

- ▶ *Internal Framework*
- ▶ *Frame Supporting the Vehicle*
- ▶ *Major Units*
- ▶ *Propelling and Controlling*



**AUTOMOBILE CHASSIS** is defined as the *Internal Framework* which consists of a *Frame Supporting the Vehicle* and all the *Major Units* responsible for *Propelling and Controlling* of the Vehicle.



## ❖ Full-forward chassis

- Complete engine is mounted inside the driver cabin
- Driver seat is just above the front wheel

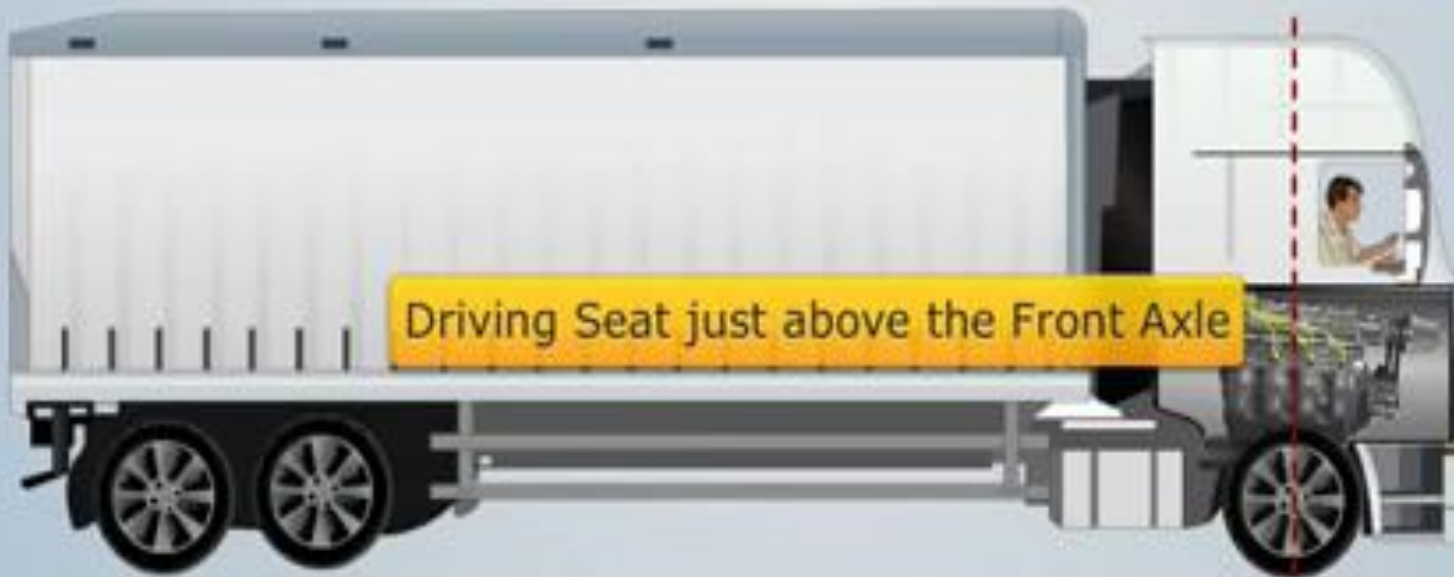
## Explain the **Automobile Chassis**?

Automobile Chassis

Full-forward Chassis

### Keywords

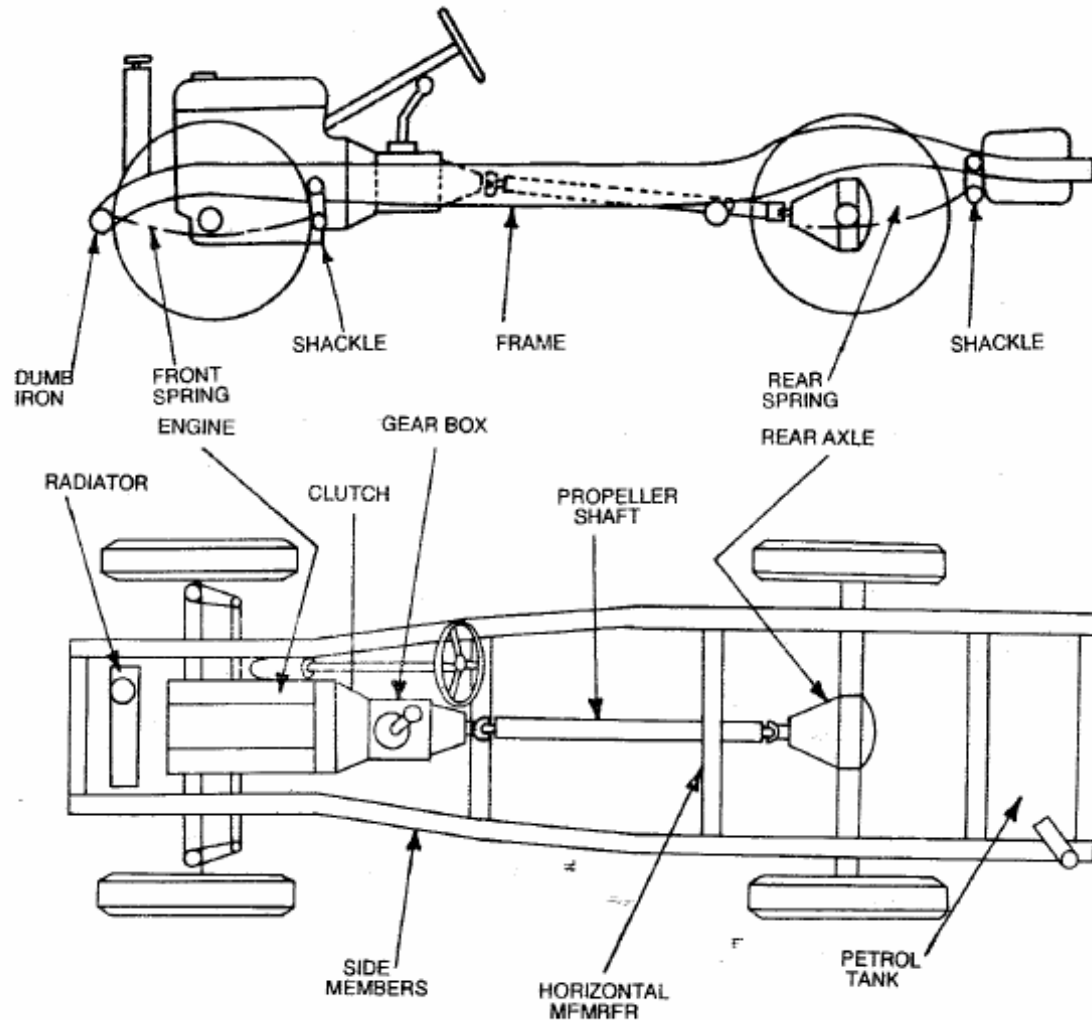
- ▶ *Internal Framework*
- ▶ *Frame Supporting the Vehicle*
- ▶ *Major Units*
- ▶ *Propelling and Controlling*



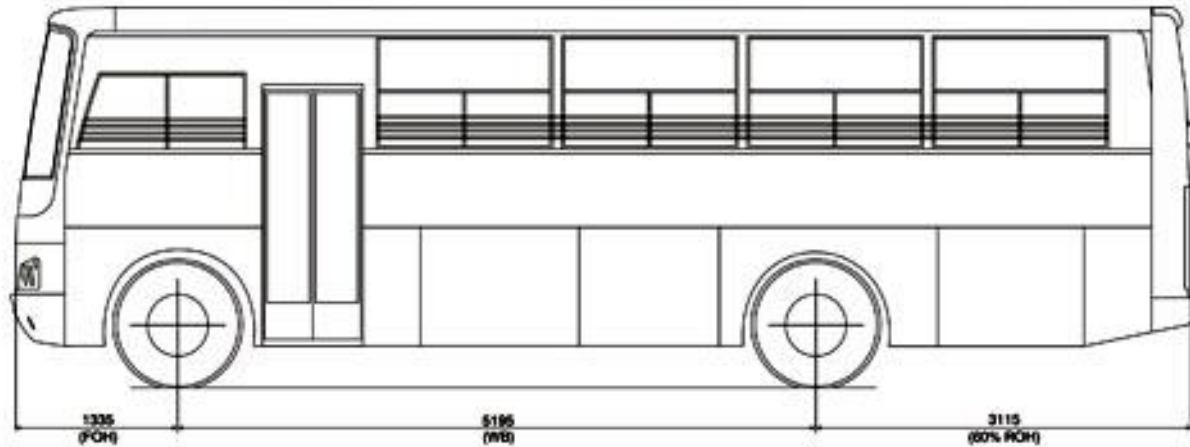
**AUTOMOBILE CHASSIS** is defined as the *Internal Framework* which consists of a *Frame Supporting the Vehicle* and all the *Major Units* responsible for *Propelling and Controlling* of the Vehicle.



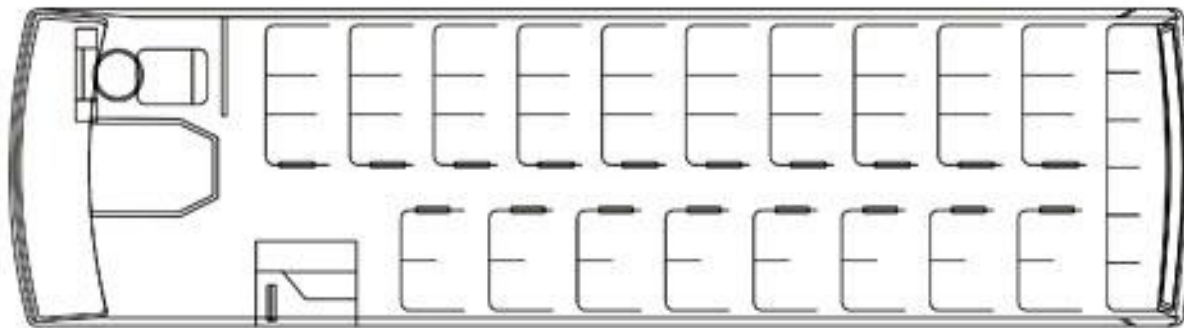
## ❖ Chassis Layouts



## Bus Chassis



CO-DRIVER SIDE VIEW



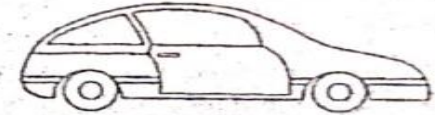
PLAN VIEW



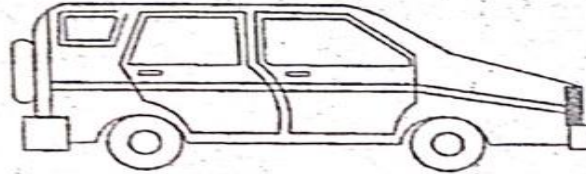
# Car Bodies



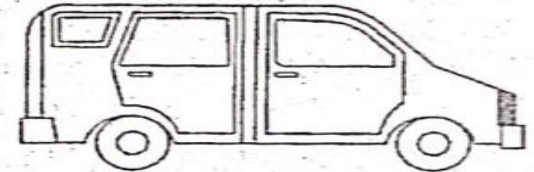
(a) Saloon



(b) Coupe



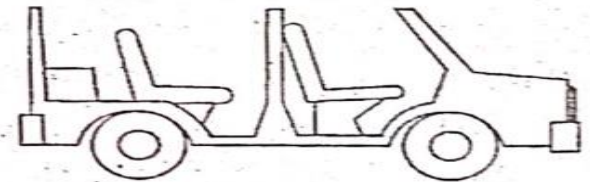
(c) Hatchback



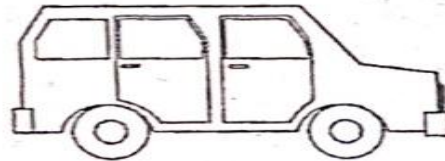
(d) Limousine



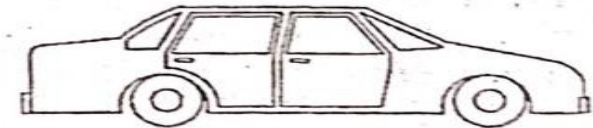
(e) Sport



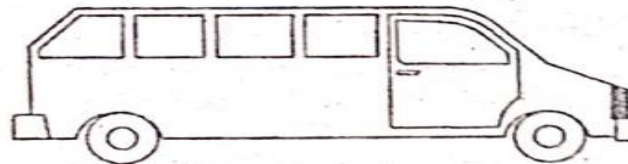
(f) Trax



(g) Jeep



(h) Estate car



(i) Station wagon

Fig. 2.11 Different types of bodies for car



## ❖ Chassis Classification Based on engine location

- Engine fitted at front
- Engine fitted at Back
- Engine fitted at centre



## ❖ Engine fitted at front:

### 1. Power is given to Rear Wheels (Rear Wheel Drive)

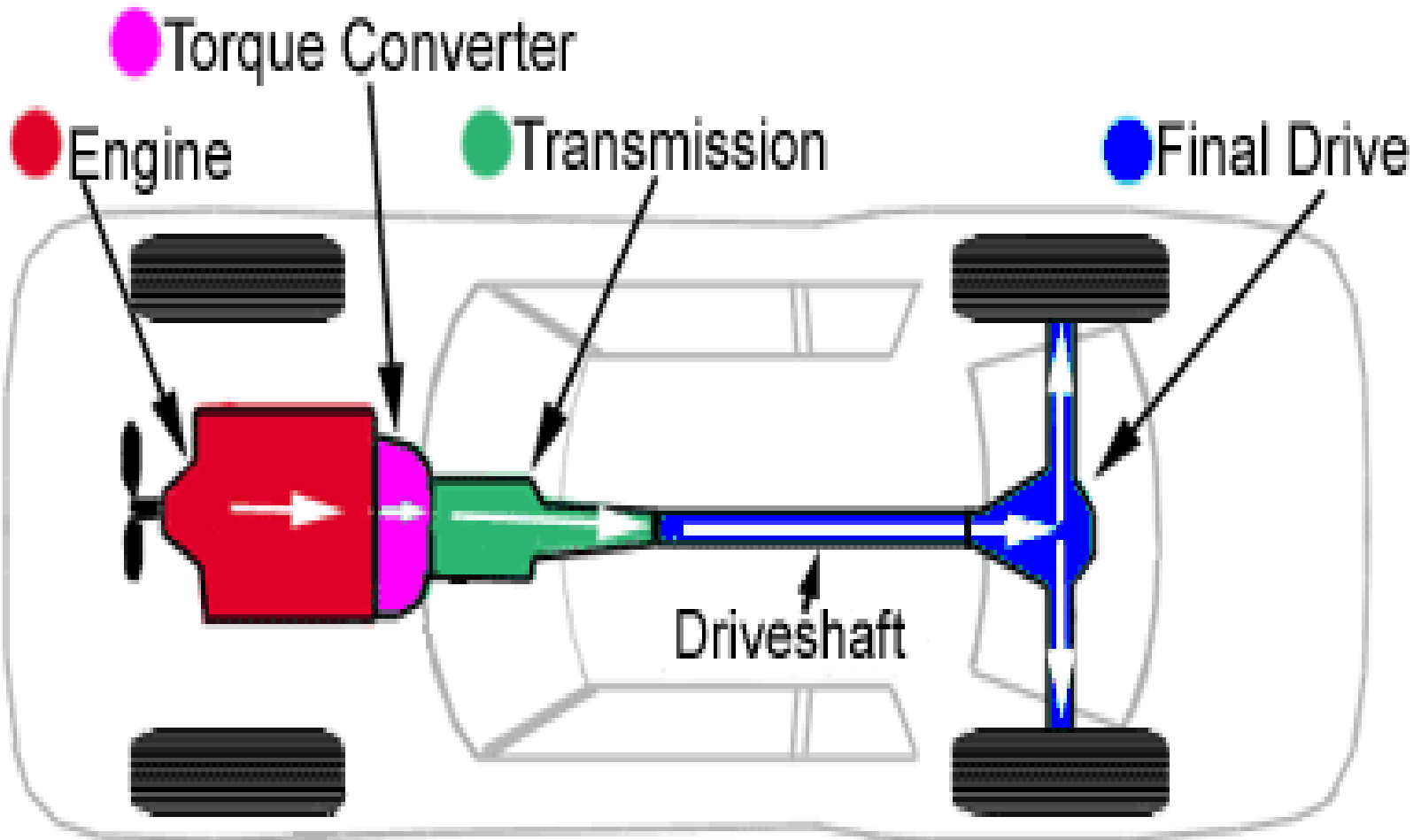
#### Advantages:

1. *Enough space is available for luggage behind the rear seat*
2. *The weight of vehicles is well balance*
3. *Increased efficiency of cooling system*
4. *Steering mechanism is simple in design*
5. *The weight of vehicle is shifted to rear driving wheels during acceleration and on steeps resulting in better road grip, hence, there are less chances of wheel slipping .*
6. *Accessibility to various components like engine , gear box and rear axle is better in comparison to other layout*



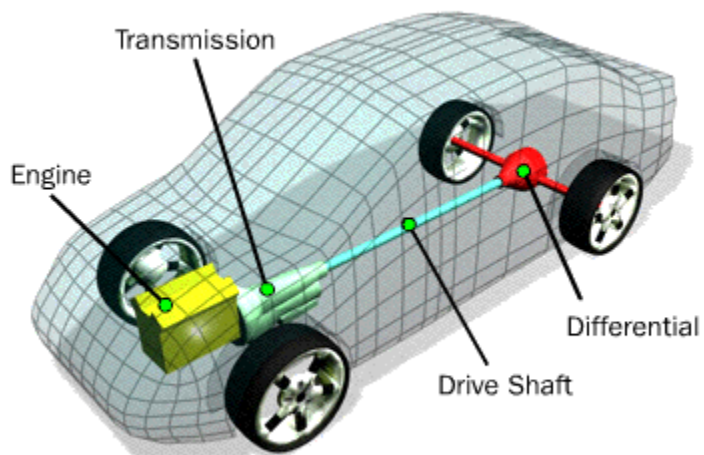
## **Disadvantages:**

1. During the braking, weight of vehicle is shifted to front wheels and weight on rear wheels decreased, results in decreased braking effort developed
2. It requires long propeller shaft and differential at rear, therefore height of floor area is increased. Also, due to long propeller shaft transmission problems and weight is increased.
3. Due to less weight on driving rear wheels, there is less adhesion on road and result in less holding capacity. Therefore there is chance of slipping on slippery surface.

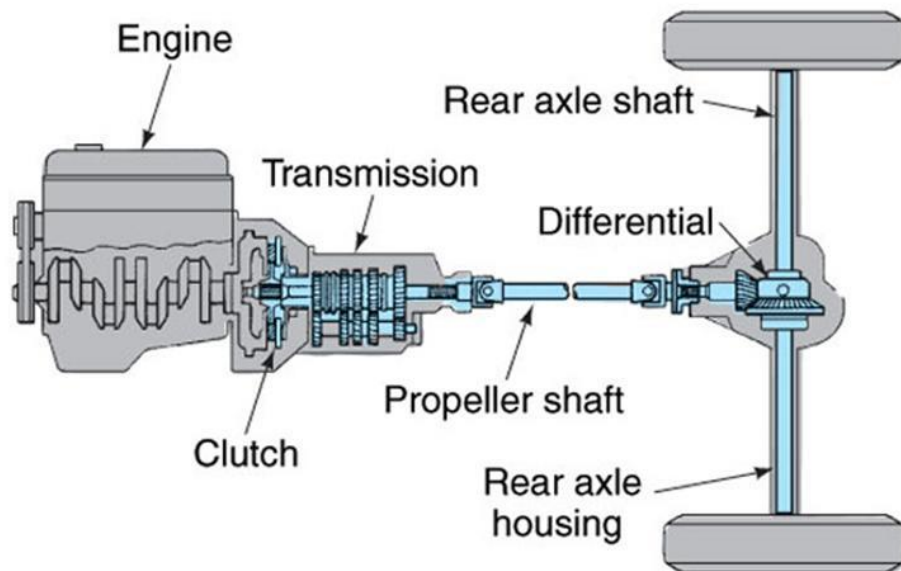
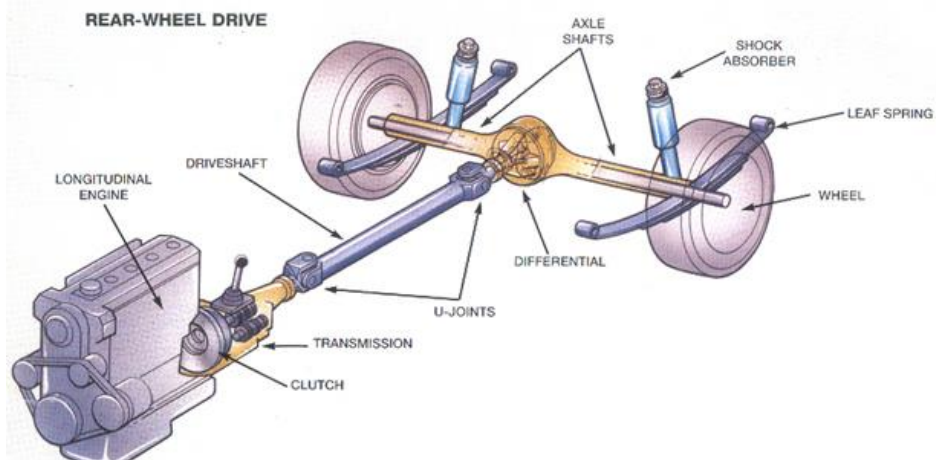


Rear Wheel Drive Layout

## Rear-Wheel Drive



© 2000 How Stuff Works







## ❖ Engine fitted at front:

### 2. Power is given to Front Wheels (Front Wheel Drive)

1. Longitudinally fitted engine
2. Transversely fitted engine

### Advantages:

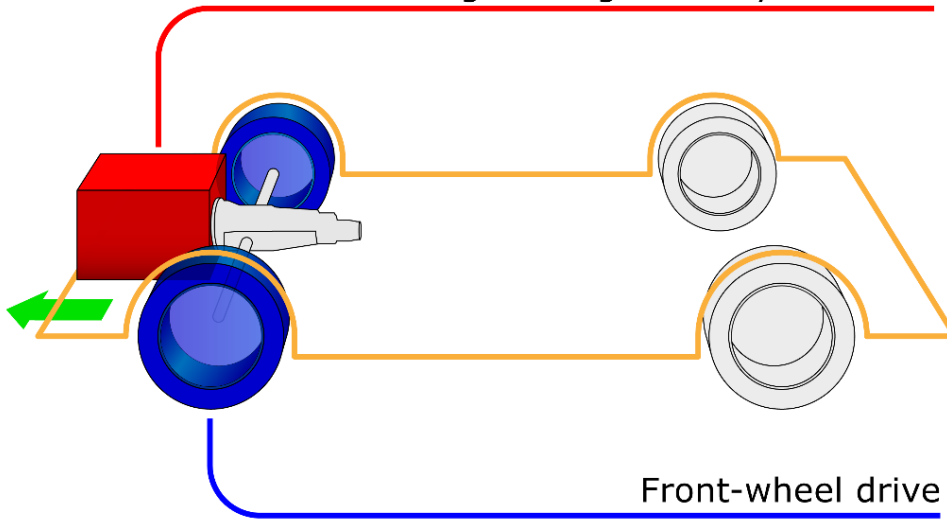
1. *Low floor is available.*
2. *clutch, gear box & differential are usually made as one unit, thereby cost is reduced.*
3. *Due to more weight placed on driving front wheel, the vehicle has more adhesion on road. Hence good road holding capacity even on the curves and slippery roads .*



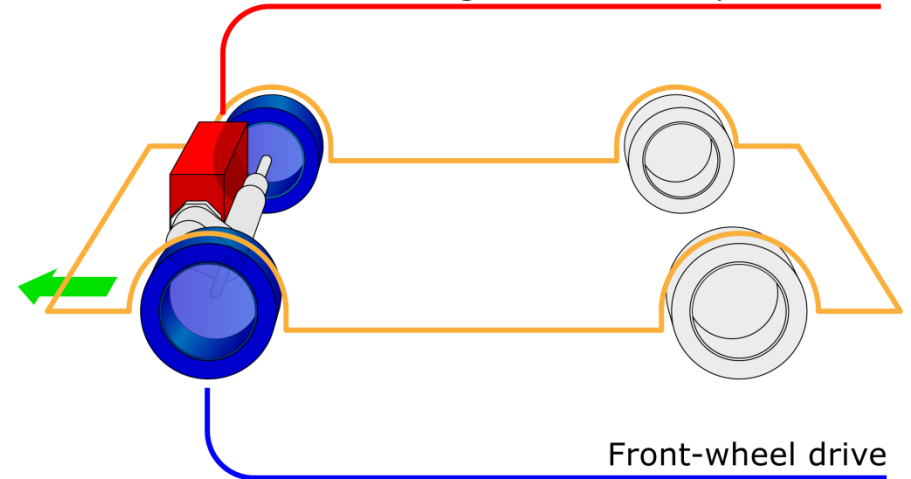
## **Disadvantages:**

1. The weight on the driving front wheels is reduced during acceleration and climbing of steep gradient due to weight of the vehicle shifting to the rear wheels. Hence, result in decreased tractive effort.
2. This disadvantage become more serious on slippery gradient.
3. The steering mechanism become more complicated due to accommodation of engine, clutch, gearbox & final drive all at front of vehicle.

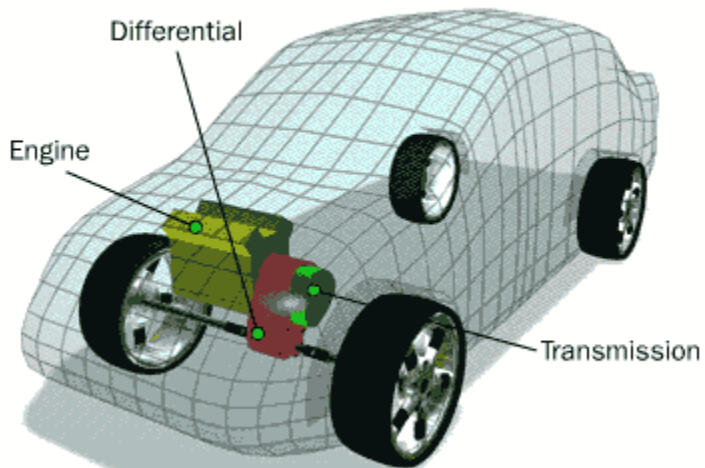
Front-engine longitudinally-mounted



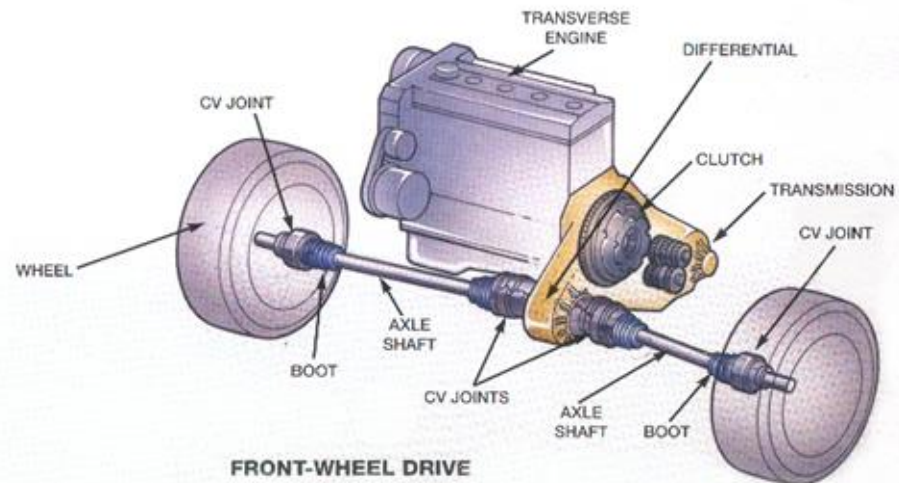
Front-engine transversely-mounted



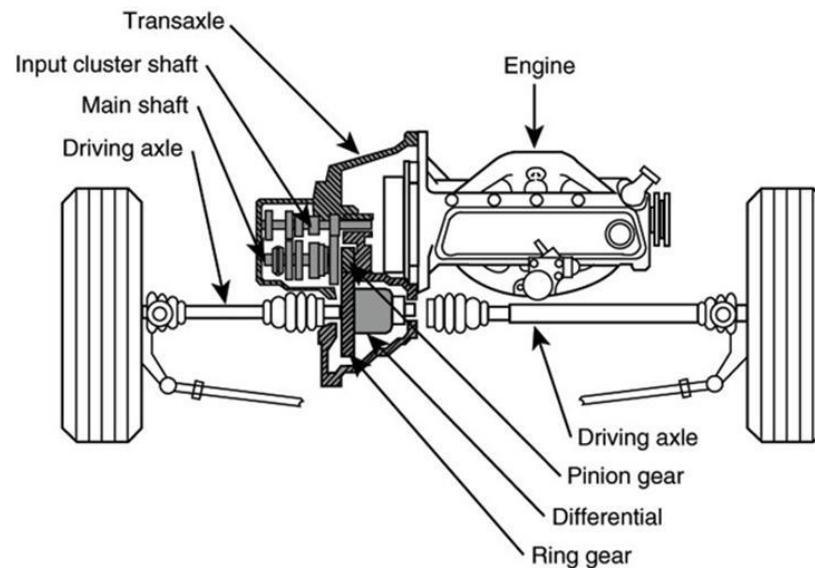
## Front-Wheel Drive



© 2000 How Stuff Works



FRONT-WHEEL DRIVE

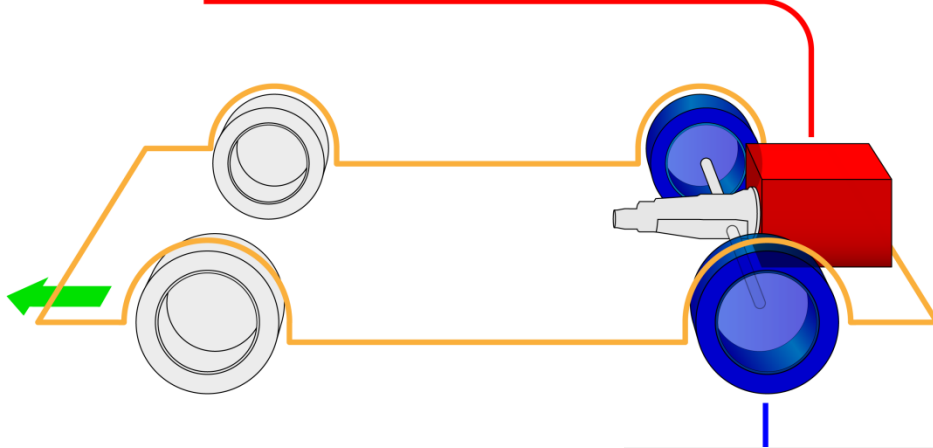




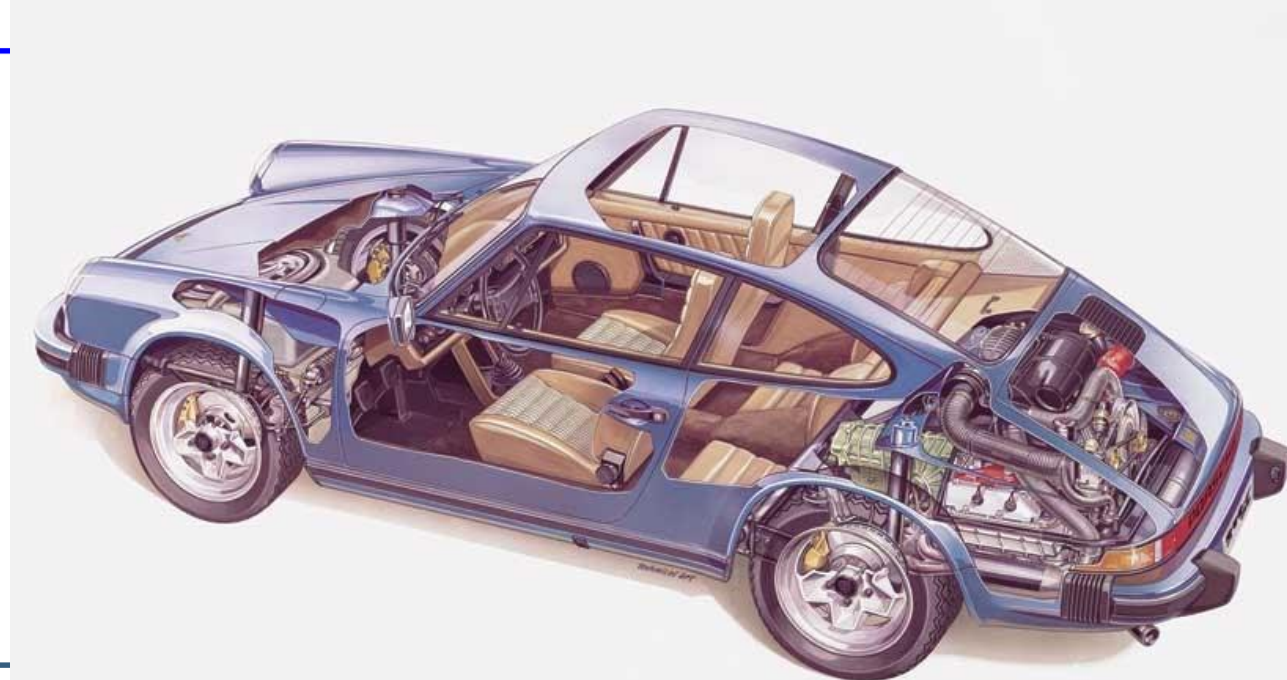
### ❖ **Engine fitted at Back:**

1. Flat floor is available since long propeller shafts are eliminated
2. With elimination of propeller shaft the centre of gravity lowered giving stable driving
3. Better adhesion on road specially when climbing hill.
4. While Climbing hills proper adhesion may be affected since the weight of vehicles moves to the rear, thereby reducing the weight on the front wheel.
5. As a result of grouping of the engine with clutch, gear box and differential, the repair and adjustment become difficult due to congestion at the rear.
6. Long linkages are required to connect the control panel and engine, gear box, accelerator and clutch.
7. Efficient cooling becomes very difficult to obtain due to air passes through side part of the body

Rear-engine



Rear-wheel drive





## ❖ Engine fitted at centre

- Drive is given to the rear
- As in royal tiger world master buses
- This arrangement provide full space of floor for use

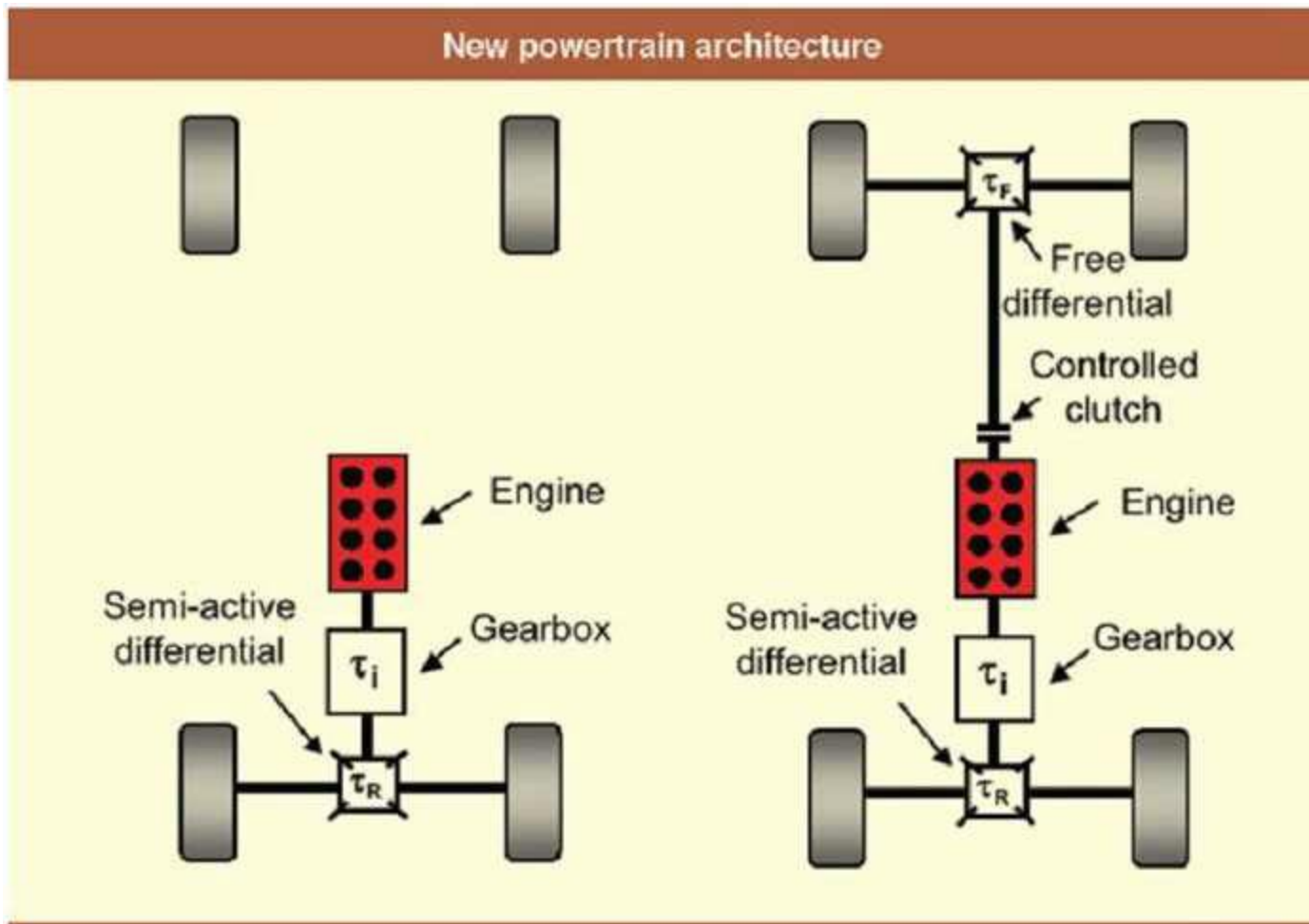
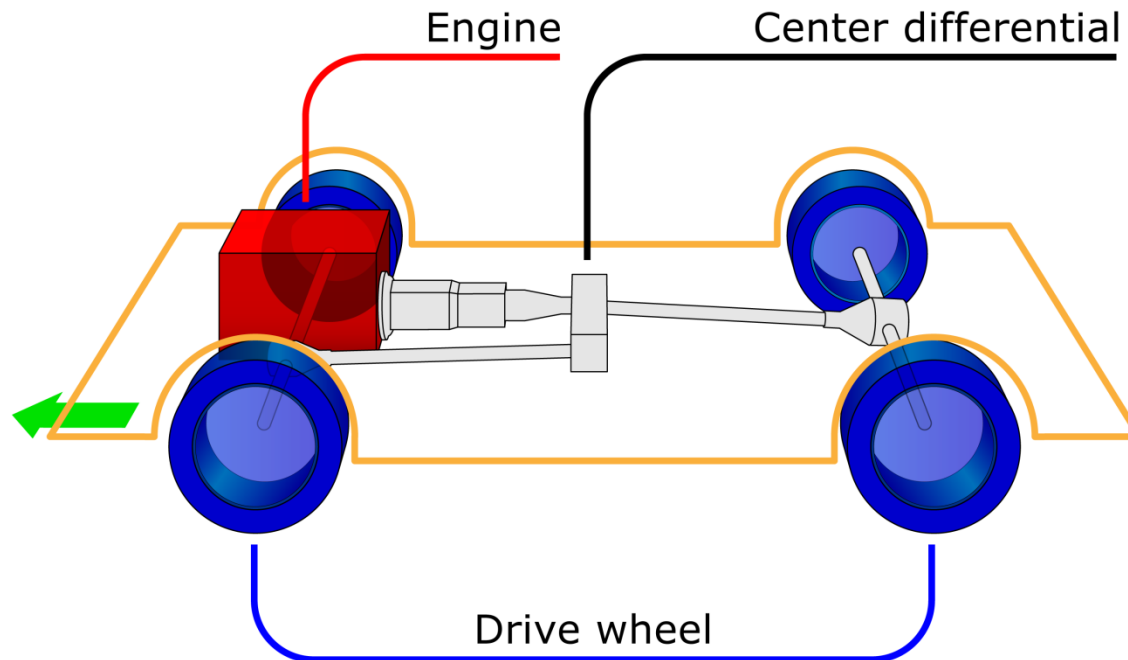


Figure 1

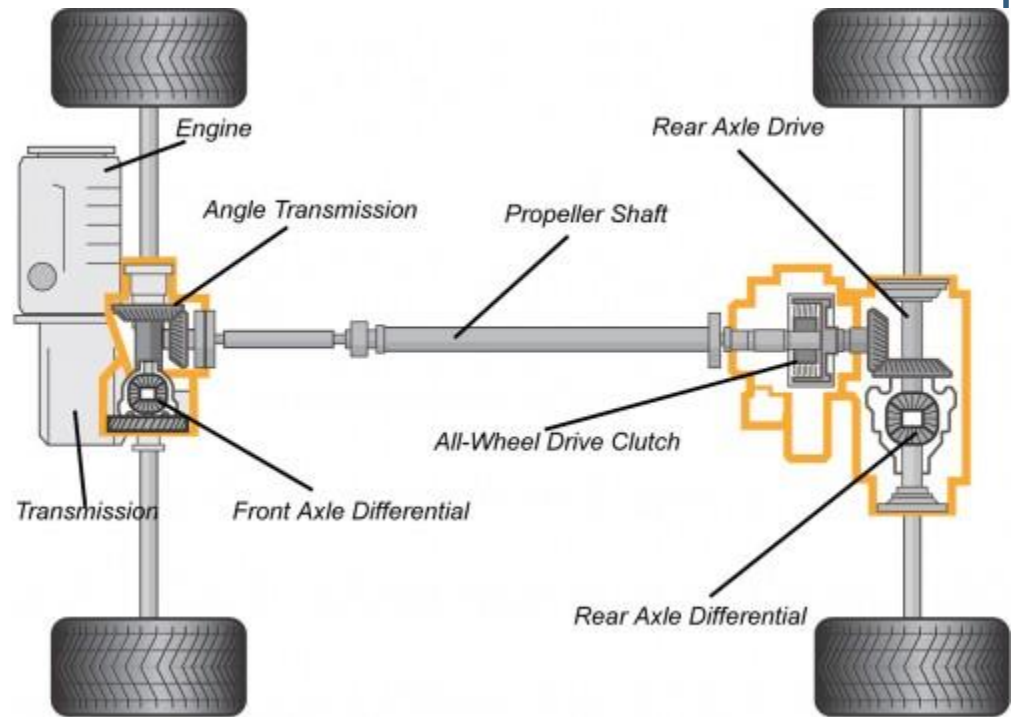
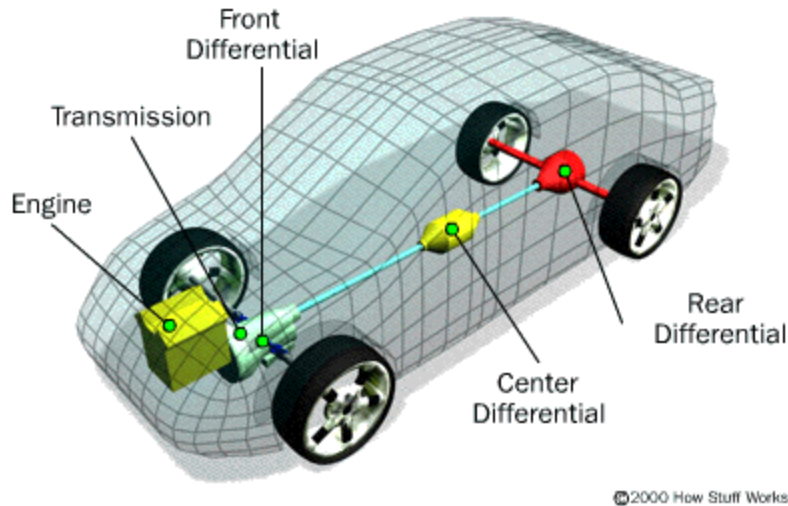


## ❖ AWD or 4WD

- **All wheel drive (AWD)** is a drivetrain configuration engineered to direct **power to all four wheels** of a car simultaneously.
- All wheel drive (AWD) train system includes a **differential** between the front and rear drive shafts.



### All-Wheel Drive



## ❖ WHY 4WD ARE USED?

- To get enough “TRACTION” between wheels and road surfaces.
- To move vehicle on slick surfaces, dirt, slippery roads, sand roads and snowy, muddy roads etc.





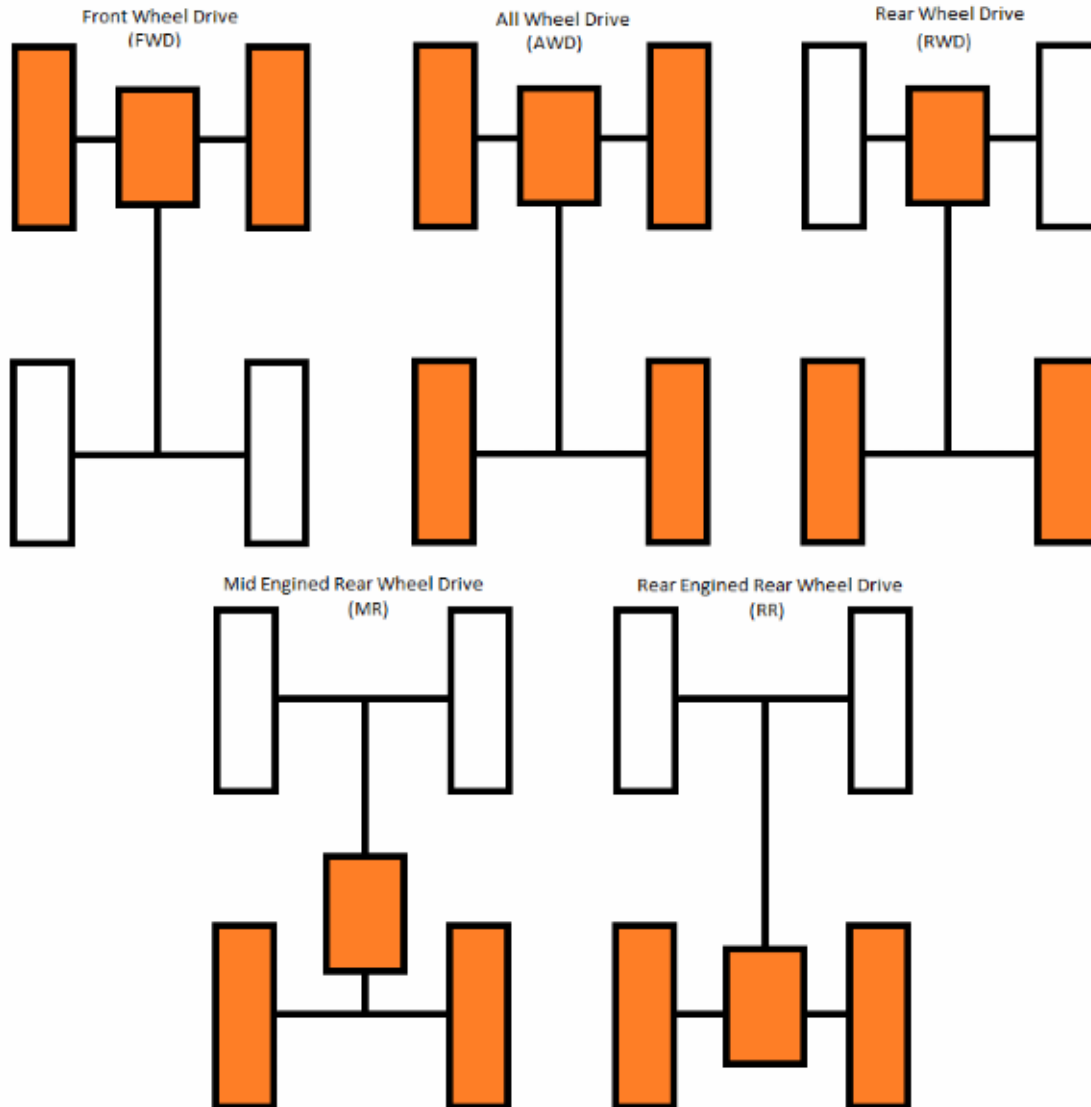
## ❖ ADVANTAGES

- Increased Traction is obtained in slippery surfaces.
- More balanced axle load distribution.
- Even tire wear.

## ❖ DISADVANTAGES

- Weight of vehicle is increased.
- Cost vehicle is increased.
- Maximum speed of vehicle is reduced.
- Less fuel economy than 2WD.

# Most Widely Used Drive Train Layouts





	Rear-wheel drive	Front-wheel drive	All-wheel drive
Production cost	Higher cost	Least cost – no propshaft or rear diff housing	Most expensive
Repair costs (if required)	Lower – gearbox or differential problems can be addressed individually	Higher – transaxle incorporates gearbox and differential together. FWD systems are now reliable enough not to require repairs to transaxle during the car's lifetime	Highest – more moving parts, more wear and tear – but transmissions are reliable and can last lifetime of car with ease
Weight	Higher	Lower – vehicle weight reduced by integrating gearbox and diff	Highest
Engine size	No limit	Limited in transverse mounted configuration by width of car – inline 4 or V8 engines at most	No limit if longitudinally mounted
Traction	Lower – lesser weight on drive wheels; compensated now with electronics, like TC, ESP	Higher – more weight on drive wheels. Weight shift to rear under heavy acceleration makes front wheels lose traction	Highest – drive to all wheels
Interior space	Lesser	Maximum – no humps on floor to accommodate propshaft, more boot space due to no differential. Compact outer dimensions due to reduced engine bay size	Space may be compromised by mechanicals intruding into cabin
Vehicle handling	Good – oversteer	Poor – understeer, torque steer	Best – still some understeer on corners, but superior grip and traction allows higher cornering speeds
Tyre load and wear	Evenly distributed compared to FWD	Acceleration, steering, braking & cornering forces together overload front tyres; very little load on rear tyres	Evenly distributed
Fuel efficiency	Lesser mileage	Better mileage	Lesser mileage



## ❖ **Motor-cycle Frames**

- The purpose of a motorcycles frame is to act as a base onto which all the various components can be bolted to.
- The engine generally sits inside the frame, the rear swing arm is attached by a pivot bolt (allowing the suspension to move) and the front forks are attached to the front of the frame.
- The frame can also help to protect the more sensitive parts of a motorcycle in a crash.
- Motorcycle frames are usually made from welded aluminum, steel, magnesium or metal alloy. Carbon-fibre is sometimes used in expensive or custom frames.



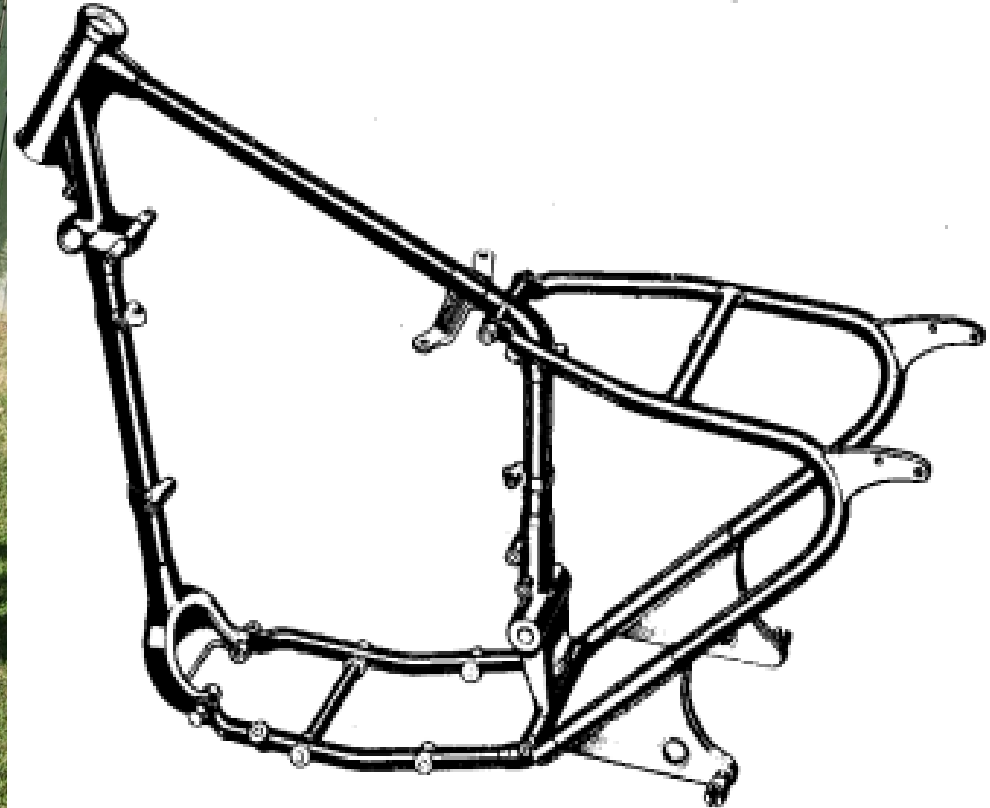
- A motorcycle frame is the backbone of the design and overall aesthetics of the motorcycle. The frame can either make or break a motorcycle's form and function.

## ❖ **TYPES OF FRAME**

- Single Cradle frame
- Double cradle frame
- Backbone frame
- Perimeter frame
- Monocoque frame
- Trellis frame



# 1. Single cradle frame



- The single cradle is the simplest type of motorcycle frame, and looks similar to the first ever motorcycle frames.
- It is made from steel tubes that surround the engine with a main tube above and other, smaller diameter tubes beneath.
- If a single cradle becomes double at the exhaust, as frequently occurs, it is referred to as a split single cradle frame.
- Single cradle frames are usually found in off-road motorcycles.

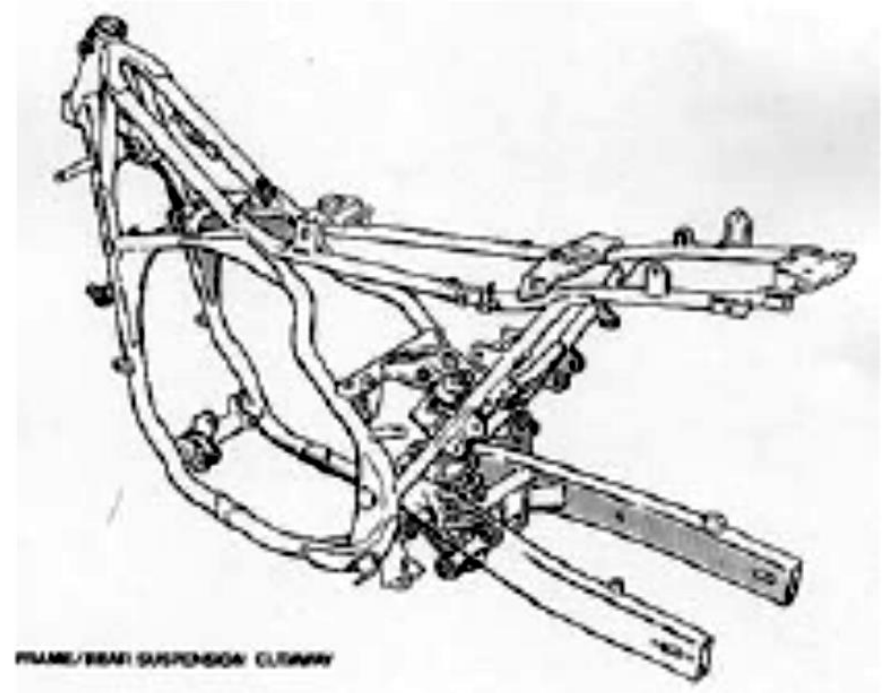
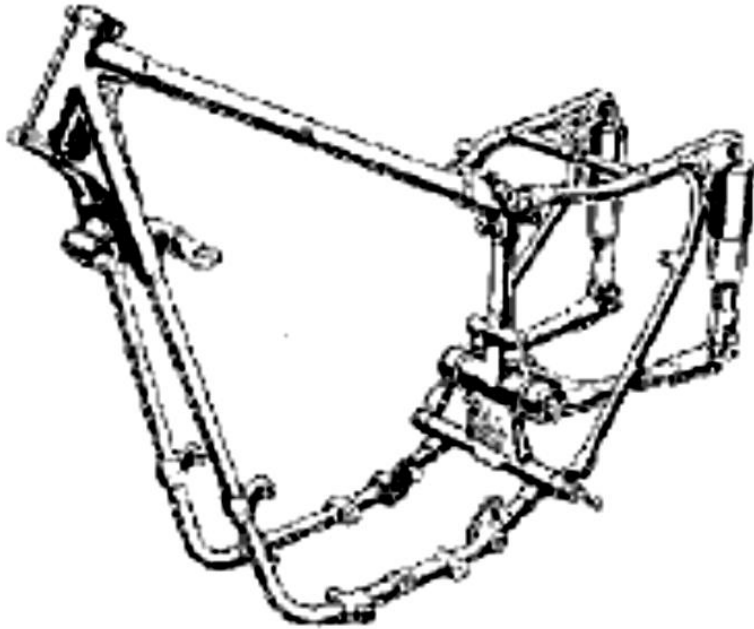


Yamaha SR500E



## 2. Double cradle frame





- Double cradle frames are descended from single cradle frames.
- They consist of two cradles that support the engine one either side.
- Double cradle frames are commonly used in custom motorcycles and simpler road bikes.
- They offer a good compromise between rigidity, strength and lightness, though they have now been technically surpassed by perimeter frames.
- Bajaj: Platina 100, Discover 100/125/150, Pulsar 150/180/220, Avenger 220
- Hero: CD Dawn/Deluxe, Splendor, Splendor NXG, Passion, Super Splendor, Glamour



Suzuki GSX600R

### 3.Backbone frame



WMX Dirt Bike



- The most desirable frame around.
- Comprises a single, wide main beam from which the engine is suspended.
- Allows for great flexibility in design, since it is concealed inside the finished motorcycle.
- The engine just seems to hang in mid air.
- It is simple and cheap to make.
- Used mainly on naked and off-road motorcycles.
- Hero Honda CD100



## 4. Perimeter frame



BBR Perimeter CRF







- Research has shown that major advantages are to be gained in terms of rigidity by joining the steering head to the swing arm in as short a distance as possible.
- Flexure and torsion are dramatically reduced.
- This is the concept behind the perimeter frame.
- Two robust beams descend in the most direct way possible from the steering head to the swing arm, passing around the engine
- These frames originated on racing motorcycles.
- They were originally made from steel but most are made from aluminum nowadays to save weight.
- Once the advantages of this frame were seen, they were adopted by most motorcycle manufacturers.
- **Bajaj Pulsar 200NS, Yamaha R15**

## 5. Monocoque frame





- Used nearly exclusively on competition bikes and is very rarely found on road-going bikes.
- Act as a single piece unit that functions as seat mounting, tank and tail section.
- Though they offer certain advantages in terms of rigidity, monocoque frames are heavy and generally not worth the effort.
- They are used almost exclusively on specialized competition bikes and are not a good choice for street bikes.
- Ducati Panigale 1199.

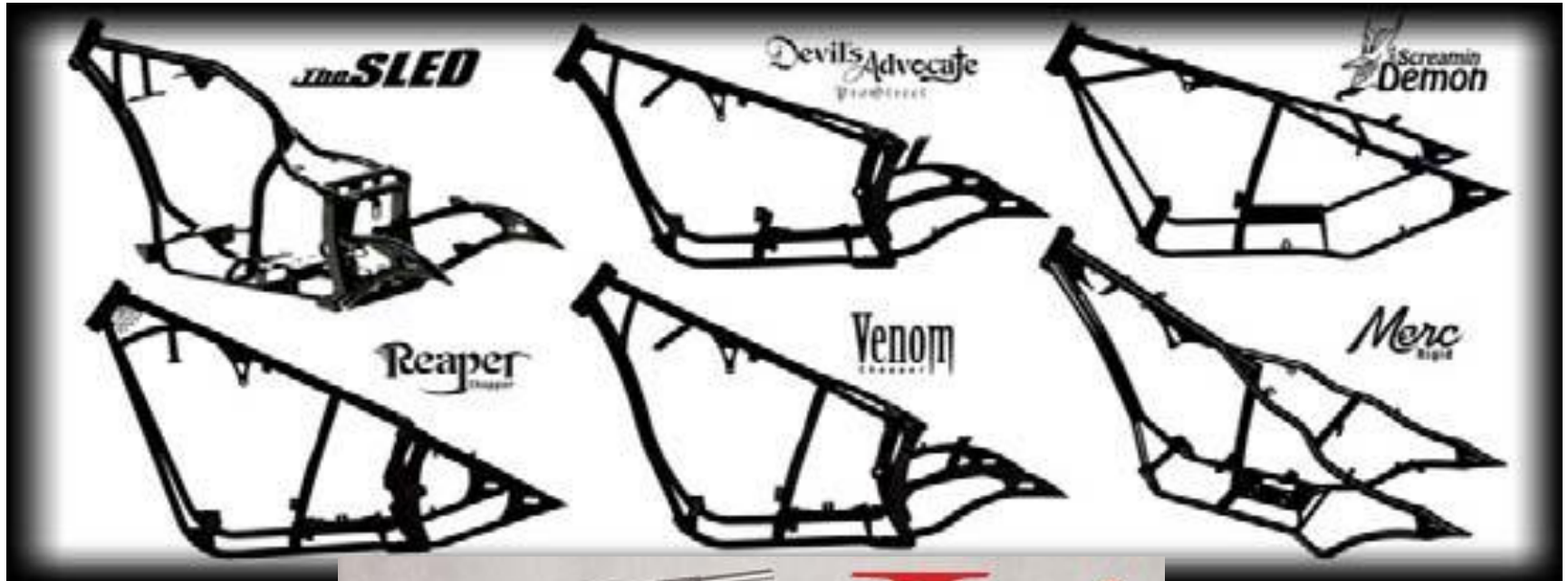
## 6. Trellis frame



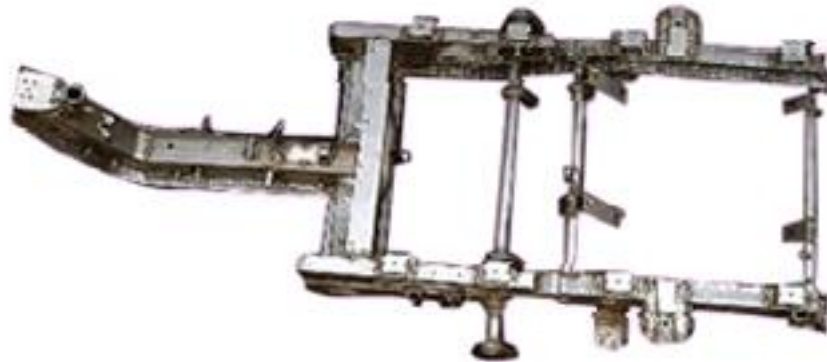


- The trellis frame rivals the aluminum perimeter frame for rigidity and weight.
- A favorite of Italian and European manufacturers it has proved a great success in racing and competition.
- The Trellis frame uses the same principles as the perimeter frame, and connects the steering head and swing arm as directly as possible.
- The frame is made up of a large number of short steel (or aluminum) tubes welded together to form a trellis.
- The trellis frame is not only easy to manufacture but extremely strong as well. The frame pictures is from the Suzuki SV650S.

## ❖ Custom Built Frames



## ❖ Three Wheeler Frames





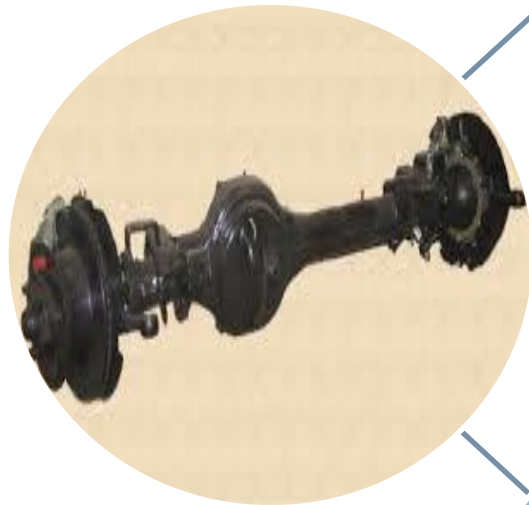
## ❖ Axle:

- An axle is a central shaft for a rotating wheel or gear.
- On wheeled vehicles, the axle may be fixed to the wheels, rotating with them, or fixed to the vehicle, with the wheels rotating around the axle.
- Bearings or bushings are provided at the mounting points where the axle is supported.





## ❖ Types of Axles



REAR  
AXLE

- Full Floating
- Semi Floating
- Three Quarter Floating

FRONT  
AXLE

- Dead Front Axle
- Live Front Axle

STUB  
AXLE

- Elliot
- Reversed Elliot
- Lamoine
- Reversed Lamoine



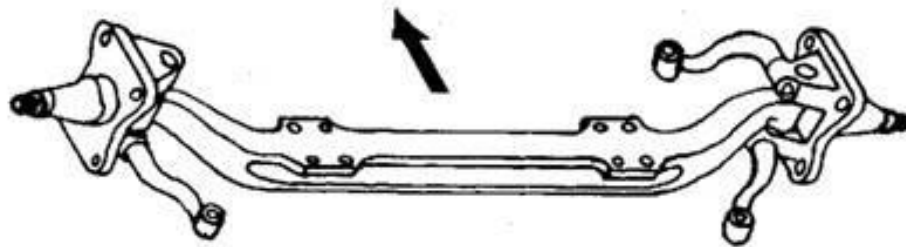
## ❖ **Front Axle:- Functions**

- It supports the weight of front part of the vehicle.
- It facilitates steering knuckles and suspension springs.
- It transmits weight of vehicle through springs to the front wheels.
- It absorbs torque applied on it due to braking of vehicle.



## ❖ Front Axle

- The front axle is designed to transmit the weight of the automobile from the springs to the front wheels, turning right or left as required.
- To prevent interference due to front engine location, and for providing greater stability and safety at high speeds by lowering the centre of gravity of the road vehicles, the entire centre portion of the axle is dropped.
- As shown in Fig. front axle includes the axle-beam, stub-axles, ack-rod and stub-axle arm.



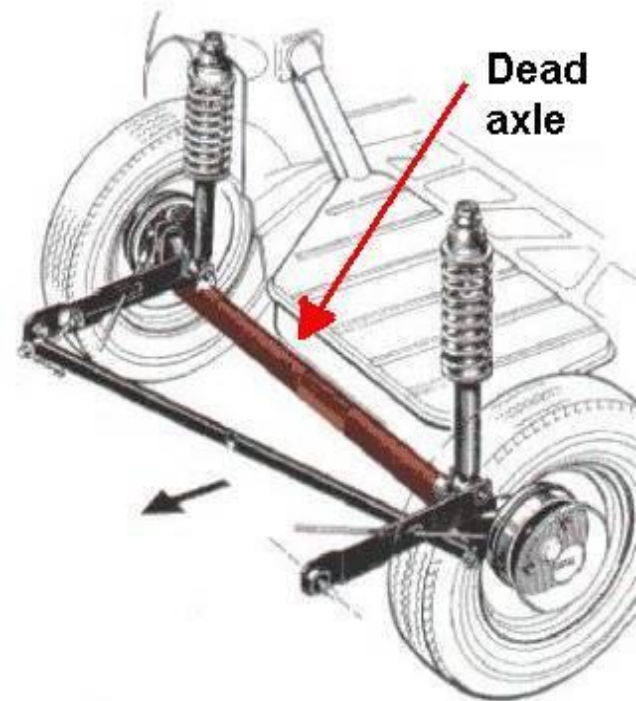


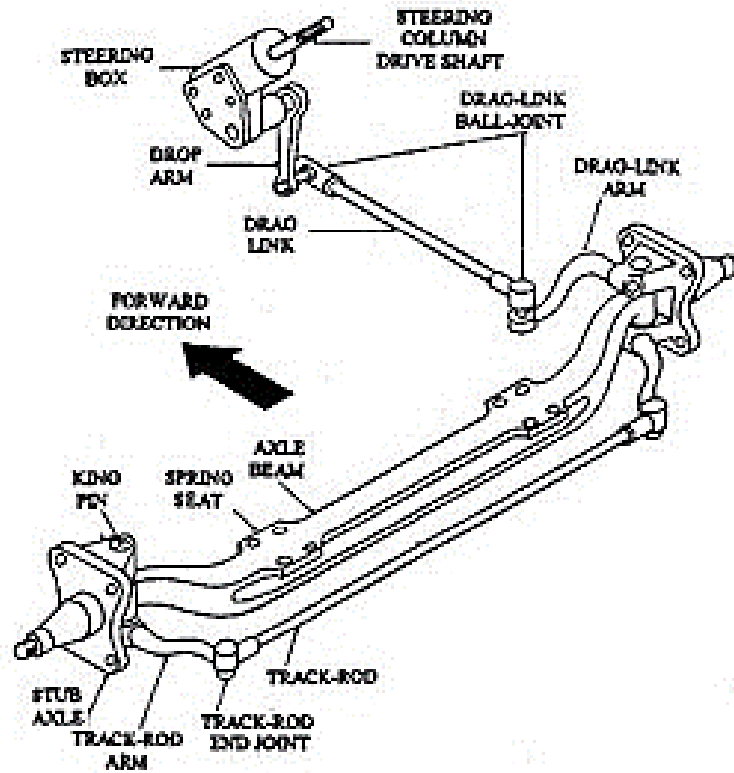
- Front axles can be live axles and dead axles.
- A live front axle contains the differential mechanism through which the engine power flows towards the front wheels.
- For steering the front wheels, constant velocity joints are contained in the axle half shafts.
- Without affecting the power flow through the half shafts, these joints help in turning the stub axles around the king-pin.
- The front axles are generally dead axles, which does not transmit power.
- The front wheel hubs rotate on anti-friction bearings of tapered-roller type on the steering spindles, which are an integral part of steering knuckles.
- To permit the wheels to be turned by the steering gear, the steering spindle and steering knuckle assemblies are hinged on the end of axle.
- The pin that forms the pivot of this hinge is known as king pin or steering knuckle pin.



## ❖ Dead Axle

- Dead axles are those axles, which do not rotate.
- These axles have sufficient rigidity and strength to take the weight.
- The ends of front axle are suitably designed to accommodate stub axles.

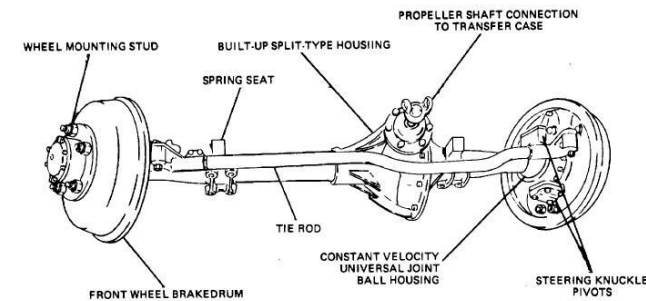
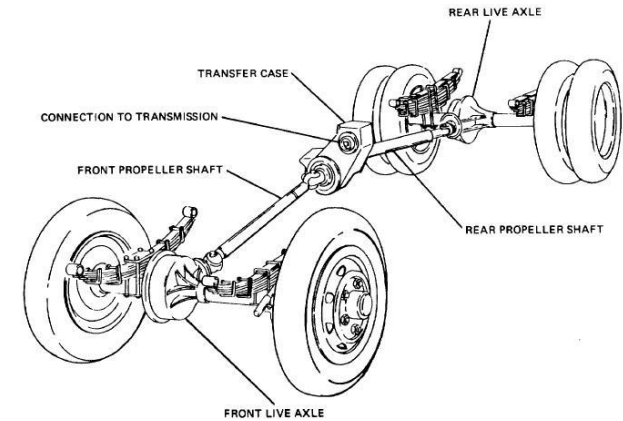




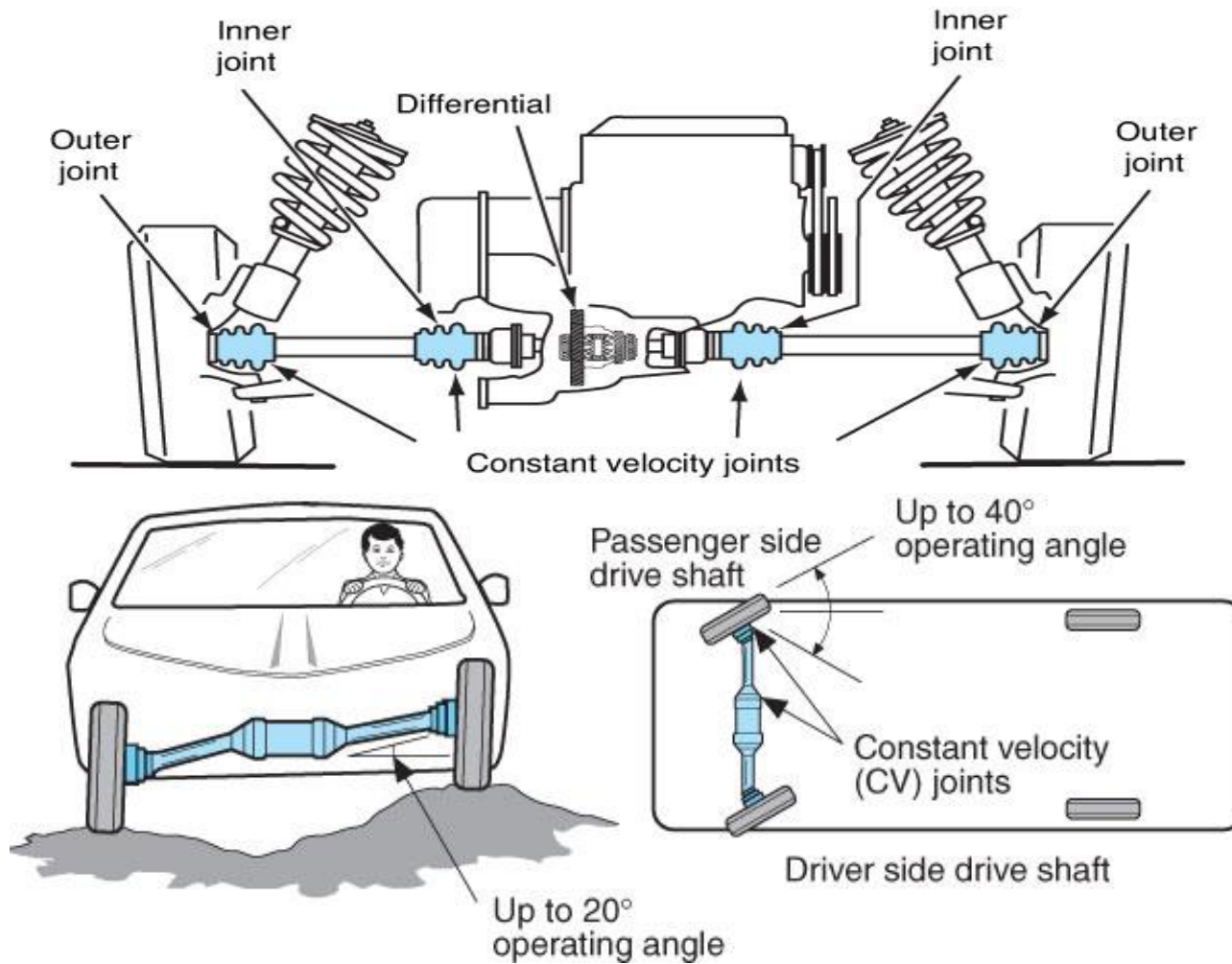


## ❖ Live Axle

- Live axles are used to transmit power from gear box to front wheels.
- Live front axles although, resemble rear axles but they are different at the ends where wheels are mounted. Maruti-800 has line front axle.



TA233





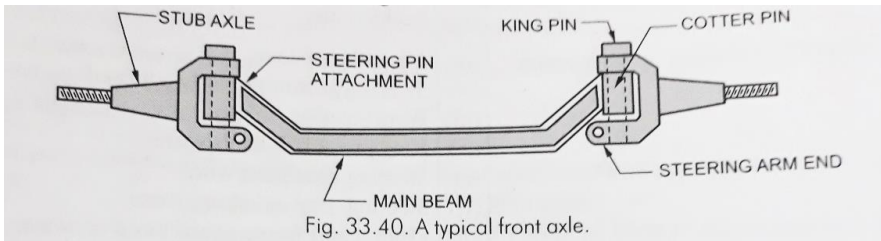


Fig. 33.40. A typical front axle.

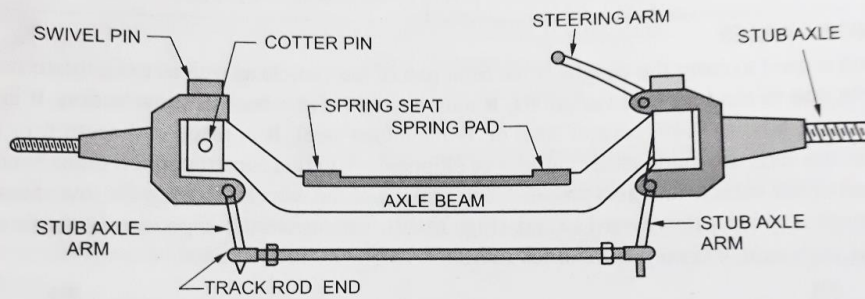


Fig. 33.41. Front axle assembly.

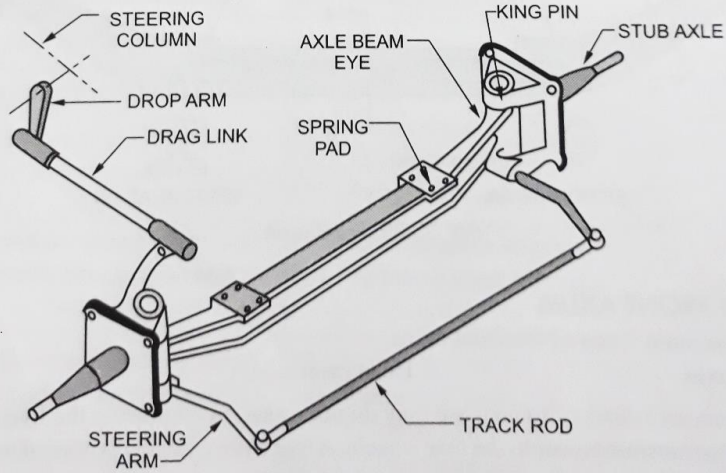


Fig. 33.42. Front axle components with steering linkage.

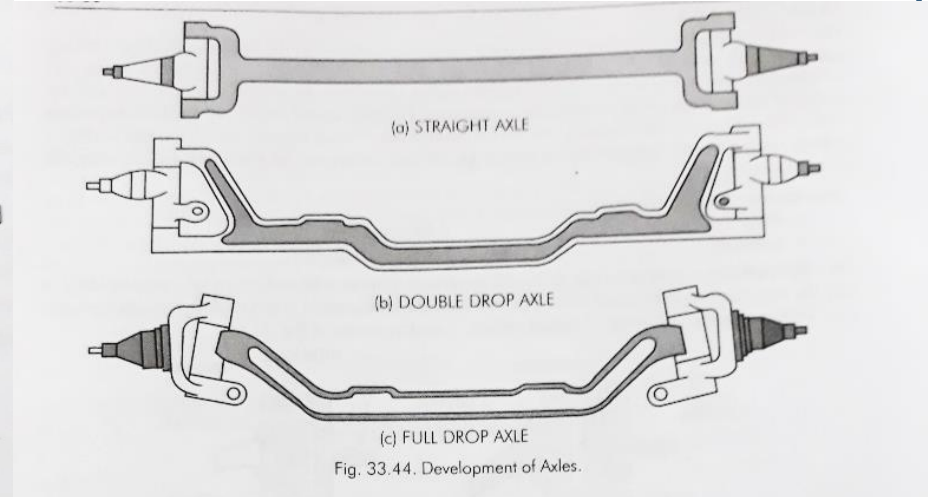
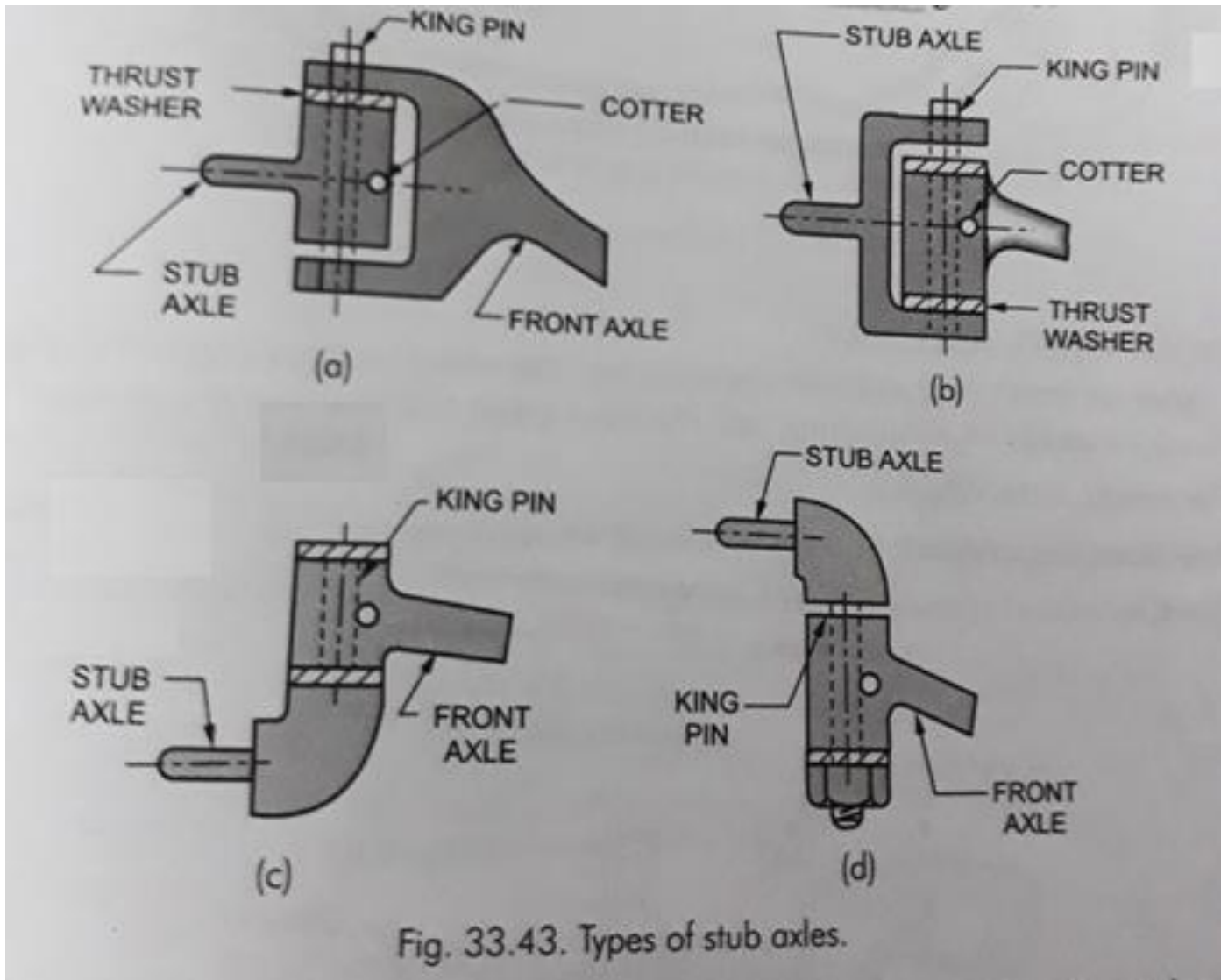


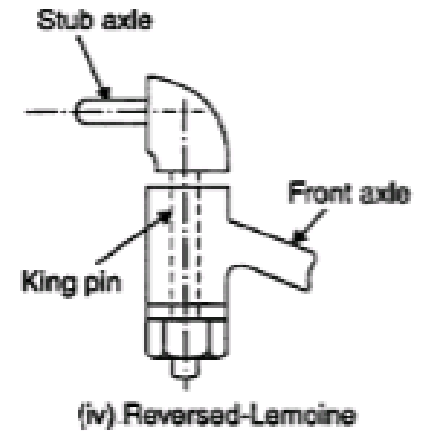
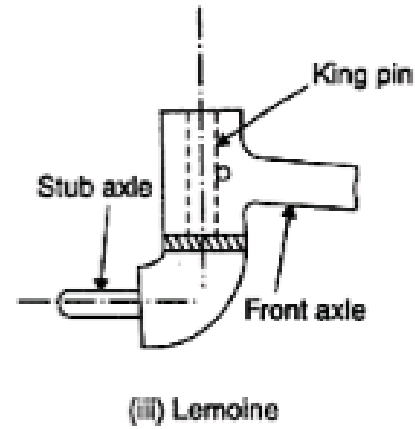
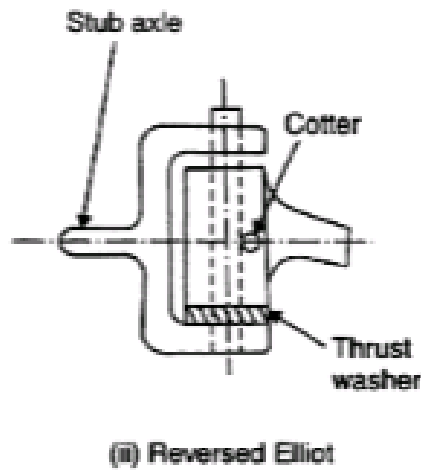
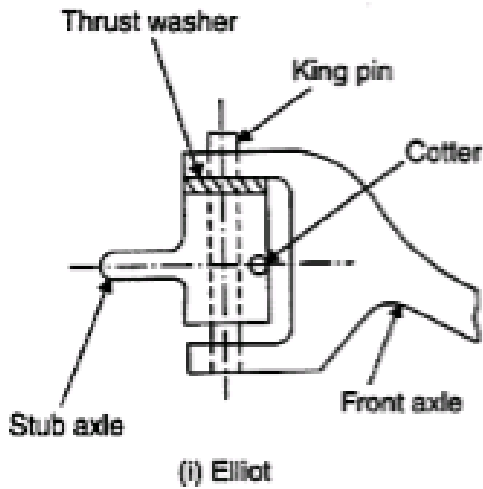
Fig. 33.44. Development of Axles.



## ❖ **Stub Axle:**

- Stub axles are connected to the front axle by king pins. Front wheels are mounted on stub axles arrangement for steering. Stub axle turns on king pins. King pins is fitted in the front axle beam eye and is located and locked there by a taper cotter pin. Stub axles are of four types:
  - Elliot
  - Reversed Elliot
  - Lamoine
  - Reversed Lamoine
- Material- 3% Nickel steel and alloy steel containing chromium and molybdenum, made by forging.





### Types of Stub Axles

## Front Wheel Assembly:

1. The weight of vehicle
2. Side thrust and tendency of the wheel to tilt when cornering
3. Shock Loads due to uneven road surfaces

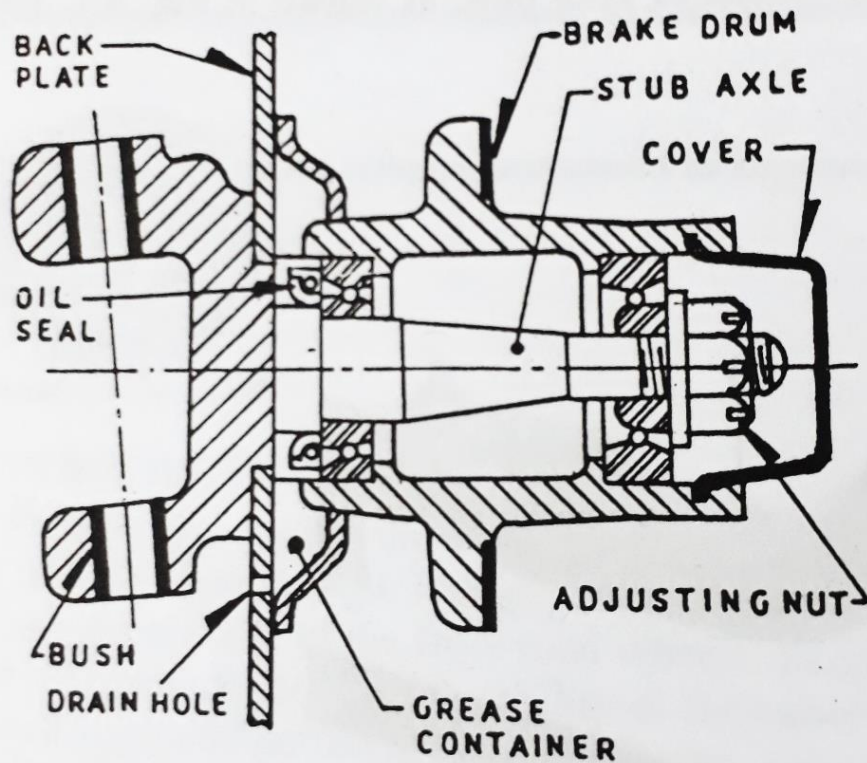
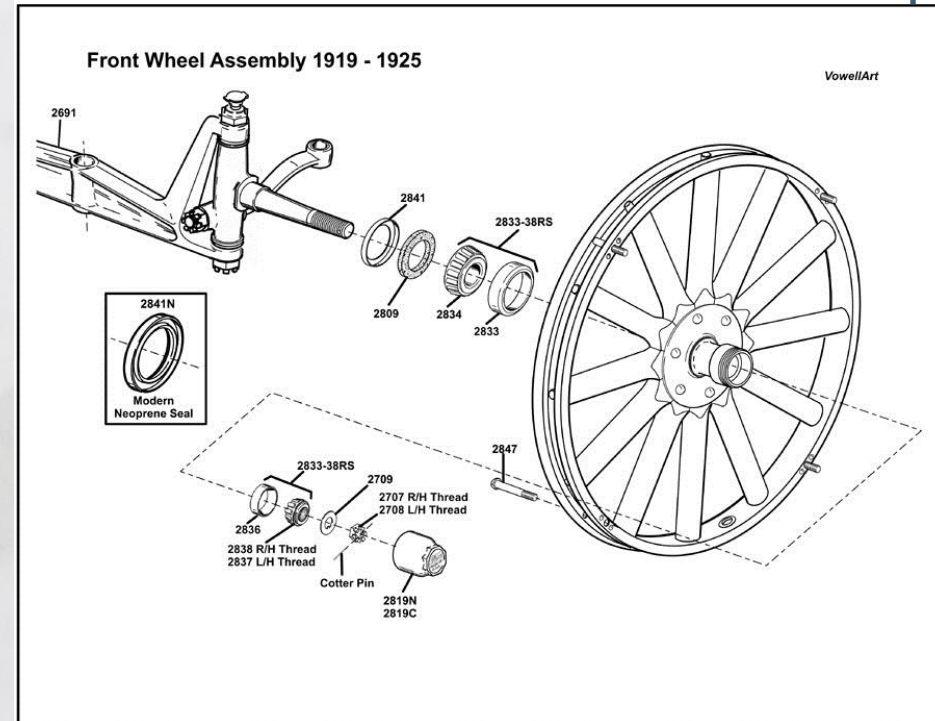


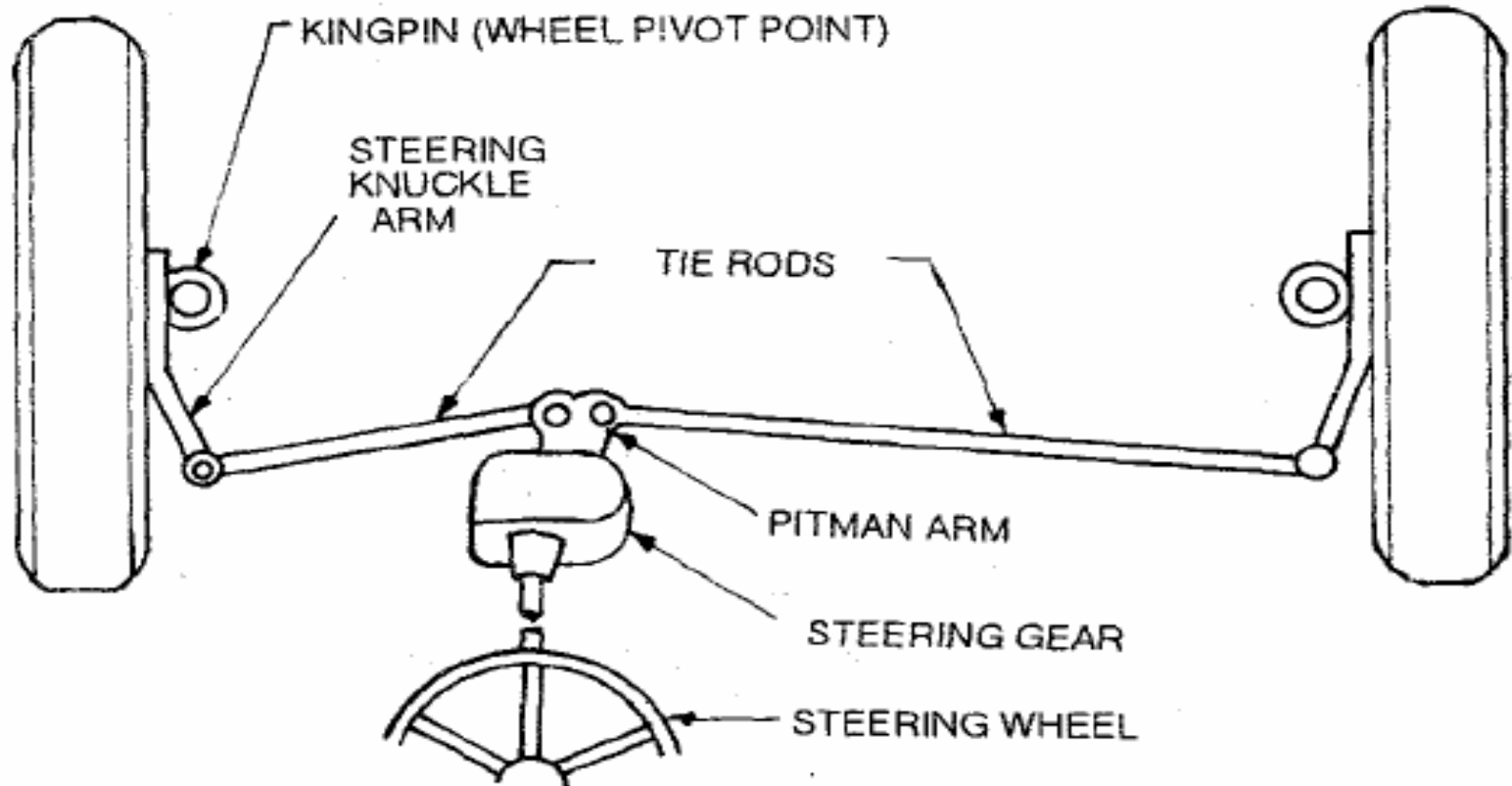
Fig. 8.5. Front wheel-stub axle assembly.





## ❖ **Steering System:**

- **Steering** is the term applied to the collection of components, linkages, etc. which will allow a vehicle to follow the desired course.
- The front wheels are supported on front axle so that they can swing to left or right for steering. This movement is produced by gearing and linkage between the steering wheel in front of the driver and the steering knuckle or wheel.
- The complete arrangement is called “Steering System”.
- The function of steering system is to convert the rotary movement of the steering wheel into angular turn of the front wheels.
- The steering system also absorb a large part of the road shocks, thus preventing them from being transmitted to the driver.





## ❖ Requirements:

- It should multiply the turning effort applied on the steering wheel by the driver.
- It should not transmit the shocks of the road surface encountered by wheels to the driver hands.
- The mechanism should have self-returning property so that when the driver releases the steering wheel after negotiating the turn, the wheel should try to achieve straight ahead position.
- It should be very accurate and easy to handle.





## ❖ **Functions:**

- It helps in swinging or turning the wheels to the left or right (at the will of driver).
- It converts the rotary movement of the steering wheel into an angular turn of the front wheels.
- It multiplies the effort of the driver by leverage in order to make it fairly easy to turn the wheels.
- It absorbs a major part of the road shocks thereby preventing them to get transmitted to the hands of the driver
- It provides directional stability.
- It helps in achieving the self-returning effect.
- Perfect Steering condition.
- Minimize tyre wear.



## ❖ Front wheel steering Geometry:

The term "*steering geometry*" (also known as "front-end geometry") refers to the angular Relationship between suspension and steering parts, front wheels, and the road surface. Because alignment deals with angles and affects steering, the method of describing alignment measurements is called steering geometry.

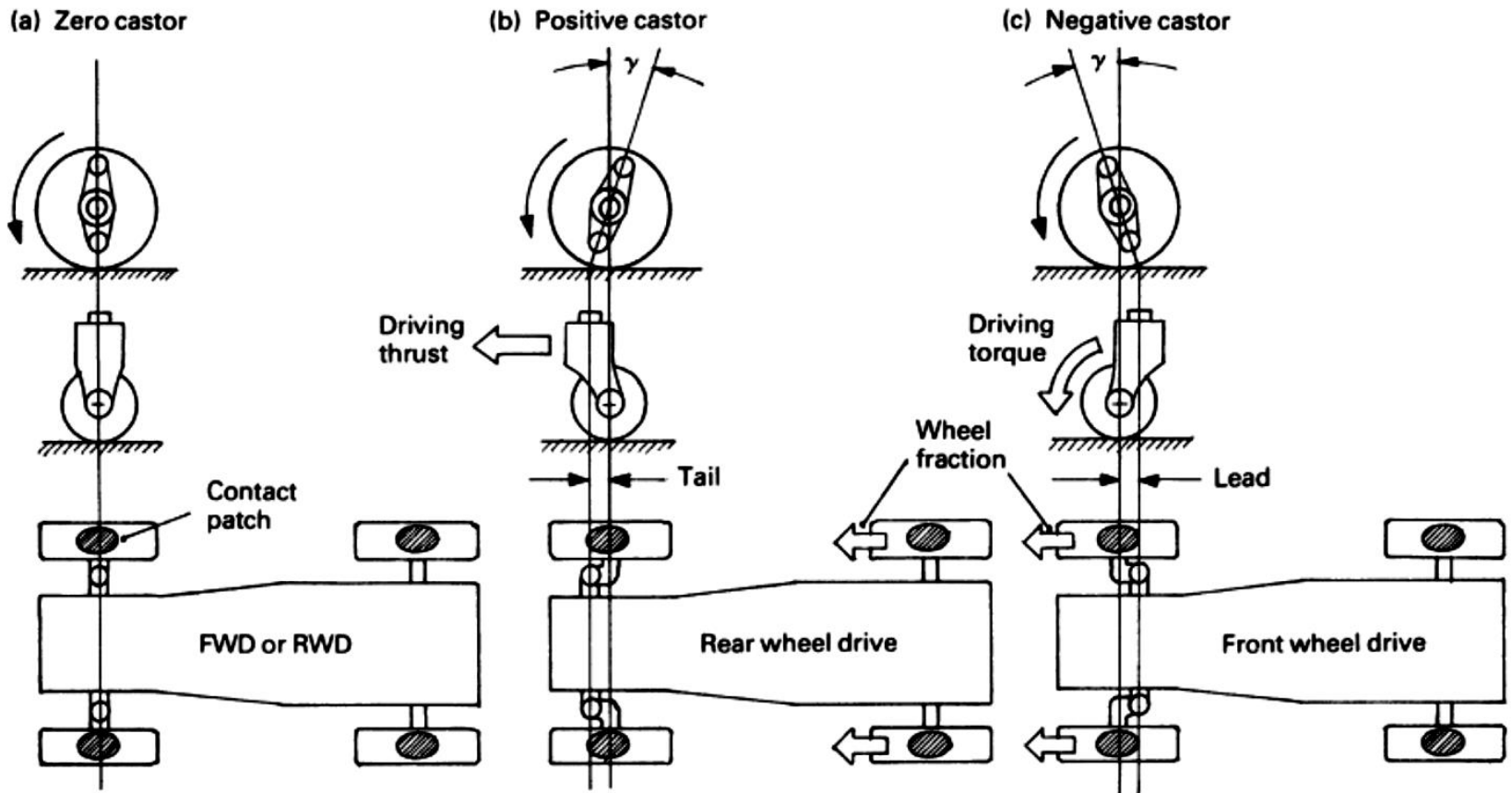
1. Castor
2. Camber
3. King Pin Inclination (Steering axis Inclination)
4. Scrub Radius
5. Toe-in or Toe- Out



## ❖ Castor Angle:-

- The inclination of king pin axis in front or rear direction so that the tire contact center is either behind or in front of the imaginary pivot center produced to the ground is known as Castor Angle.
- The angle between the king pin axis and the vertical, in the plane of the wheel is called as castor angle.
- 2 to 8 Degrees.

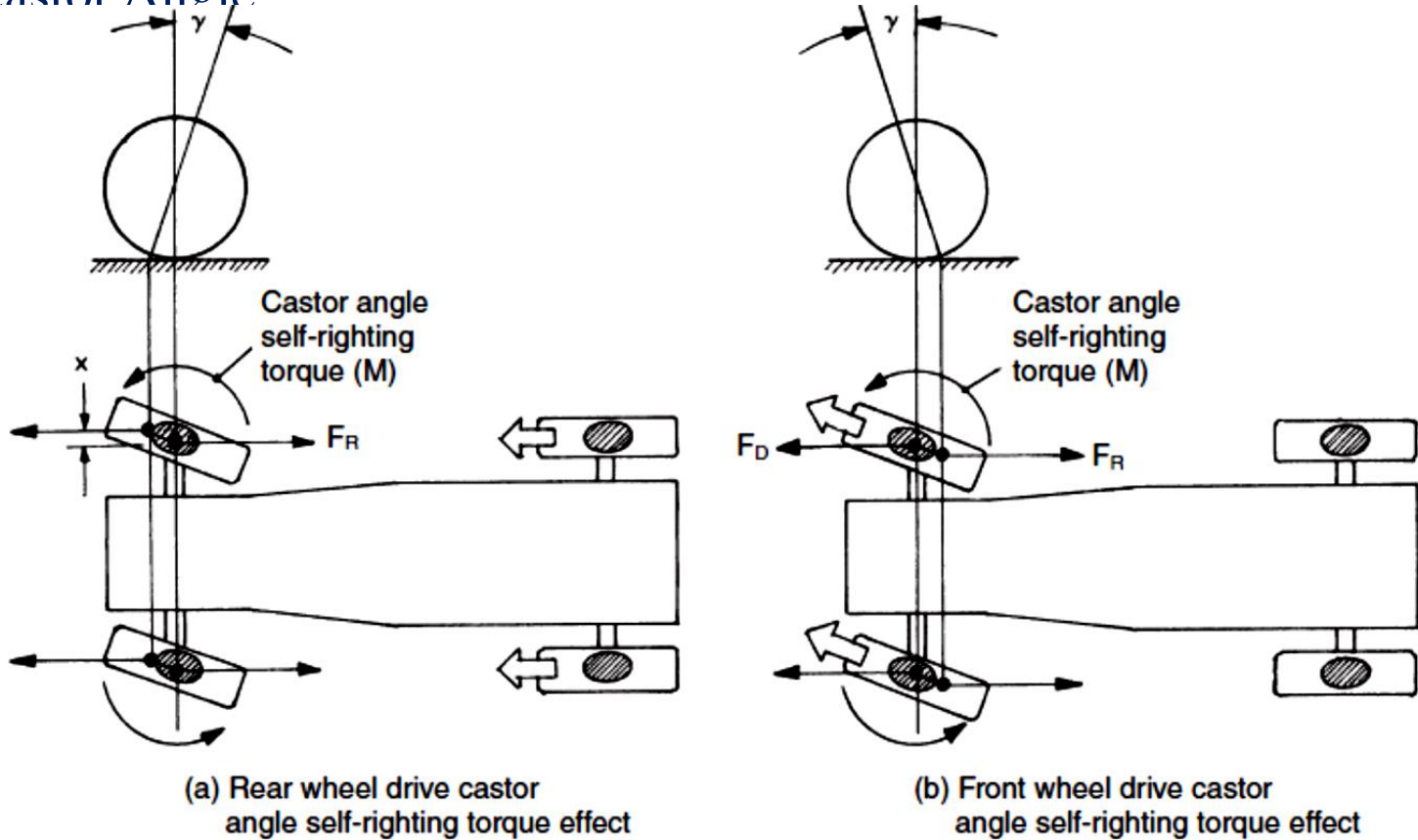




**Fig. 10.8** Castor angle steering geometry



## Effect of Castor Angle:

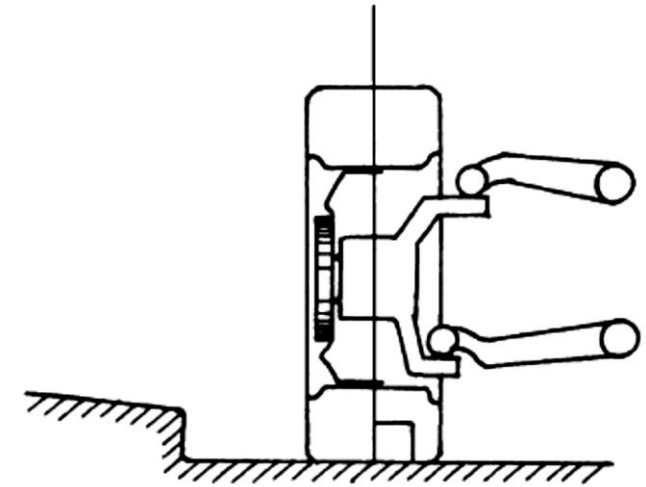


**Fig. 10.9(a and b)** Illustration of steered wheel castor self-straightening tendency



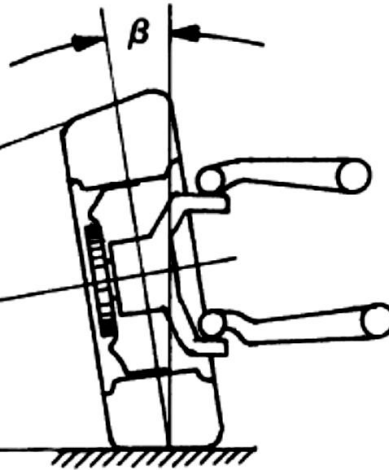
## ❖ Camber Angle:

- The angle between center line of tire and the vertical line when viewed from front of the vehicle is known as Camber Angle.



Road camber

$\beta = \text{Camber angle}$

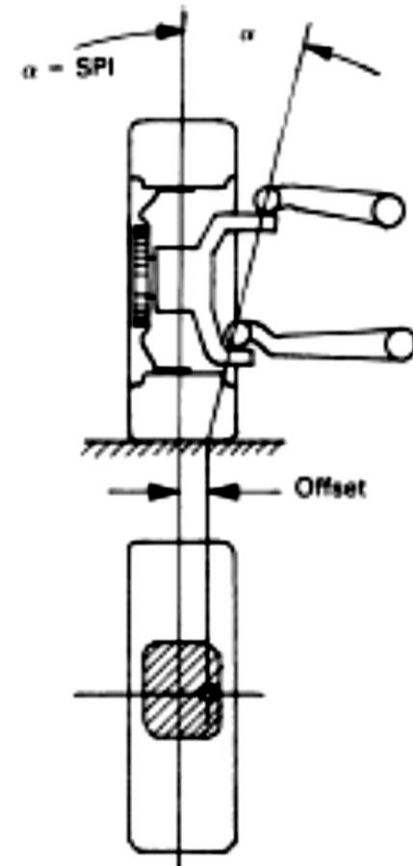
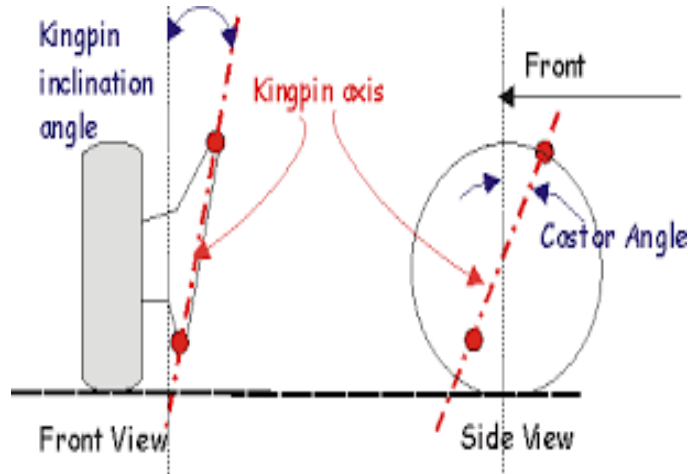




- If the top of the wheel (when viewed from front) leans outward than bottom it is positive camber conversely if bottom of the wheel is outward than the top it is negative camber.
- Generally, it should not exceed 2 Degrees.
- Positive camber is used on most of vehicles.
- Positive camber increases steering effort.
- Negative camber is used on racing cars to provide directional stability and reduce steering effort.

## ❖ King Pin Inclination or Steering Axis Inclination:

- The angle between the vertical line and the center of the king pin or steering axis when viewed from front off the vehicle is known as KPI or SAI.
- The KPI in combination with Castor angle is used to provide the directional stability in modern cars by tending to return the wheels to straight ahead position after any turn.
- This inclination varies from 4 to 8 degree in modern cars.







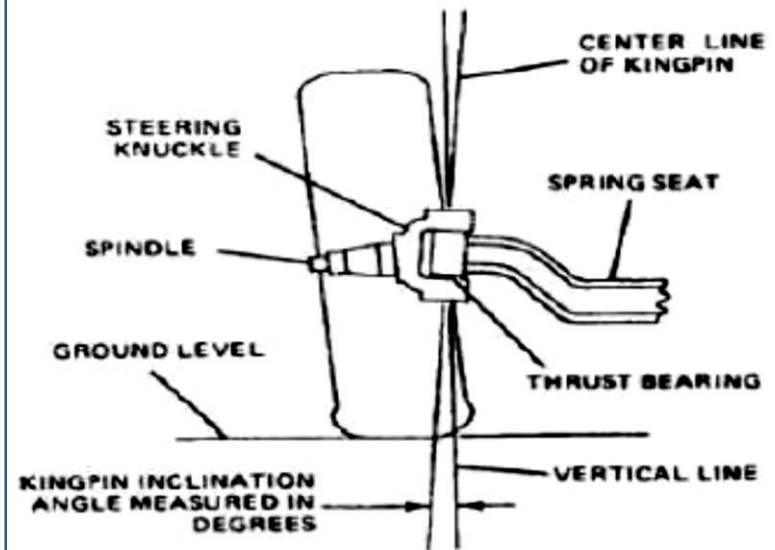
This inclination,

- Helps in a straight ahead recovery and provides directional stability
- Reduces the wear and tear of the tyres
- Tends to reduce the effect of road shock on the steering system

Incorrect steering inclination leads to,

- Hard steering
- Pulling of vehicle to a side
- Wheel doesn't return to straight ahead position

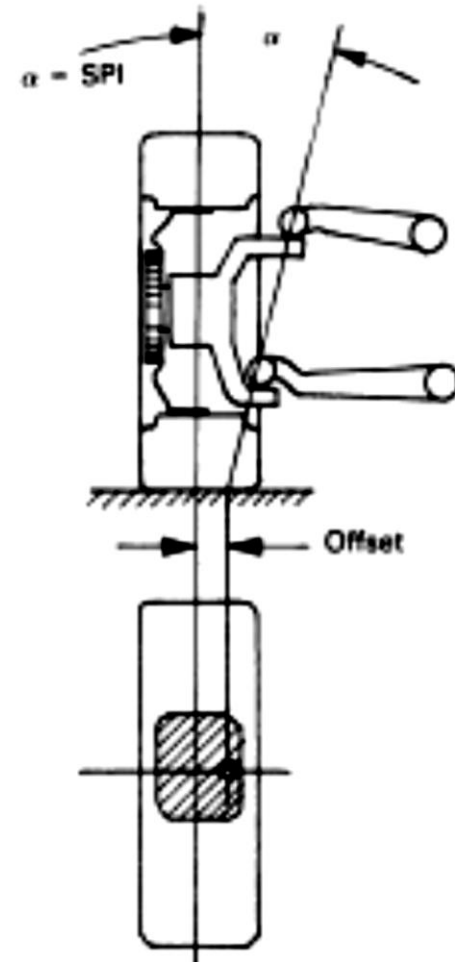
## Kingpin inclination





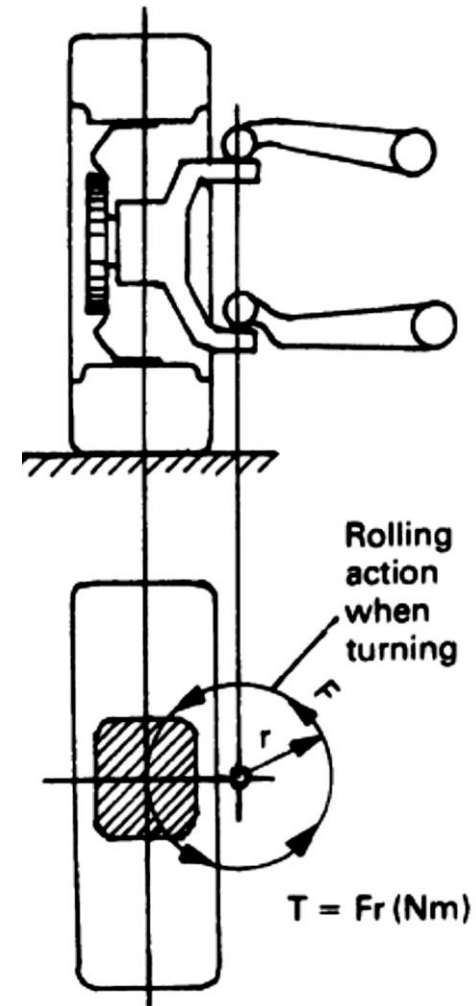
## ❖ Scrub Radius:

- The offset between the pivot center of king pin and contact center is known as the scrub radius.
- When turning the steering the offset scrub produces a Torque  $T$  by to product of radius  $r$  and opposing ground reaction force  $F$ . (i.e.  $T = Fr$ )
- A large offset requires a big input torque to overcome the opposing ground reaction force therefore the steering will tend to be heavy.
- Zero offset prevents a tread rolling and instead causes to scrub as the wheel is steered so that at low speed the steering also has heavy response.



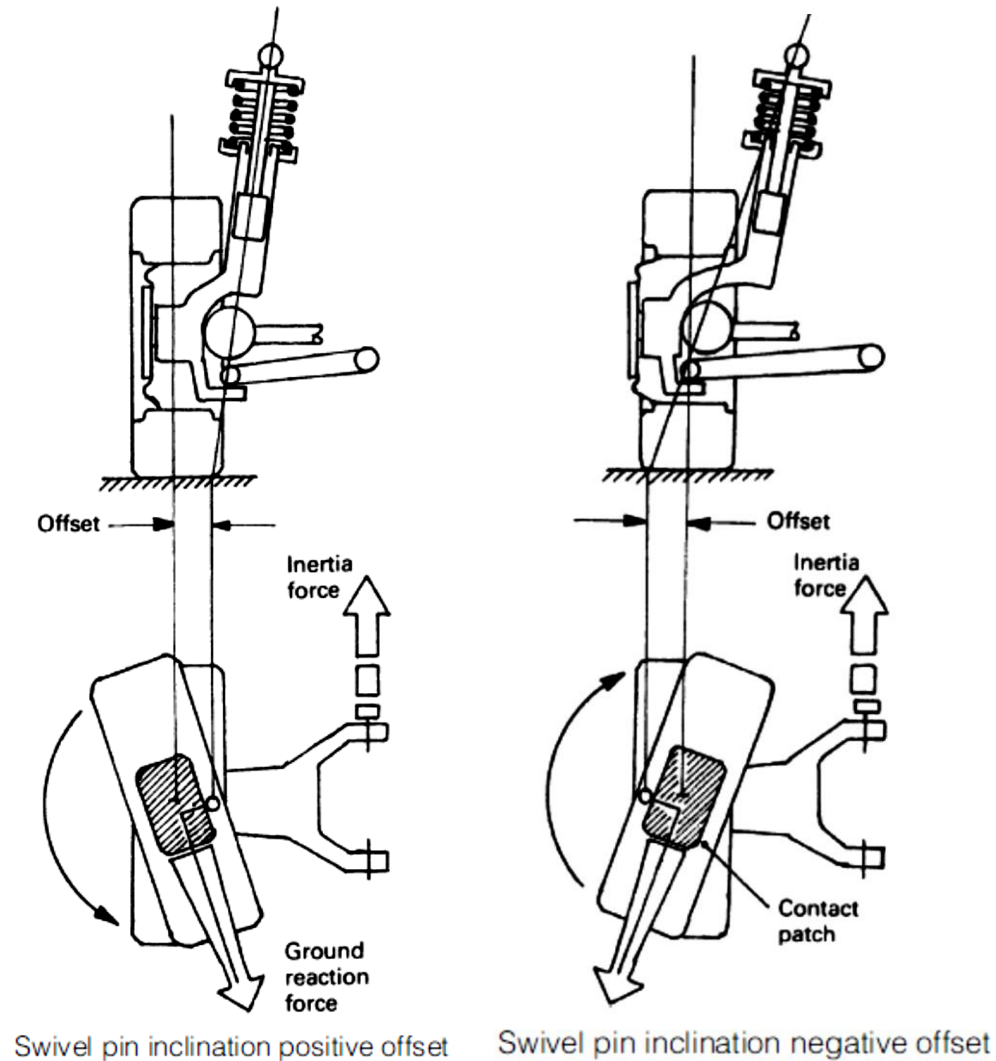


- A compromise is usually made by offsetting the pivot and the contact center to roughly 10 to 25 % of the tread width of standard sized tyres.
- This small offset permits the pivot axis to remain within the contact patch, thereby enabling a rolling movement to still take place when the wheels are pivoted so that the tyre scruff and creep (Slippage) are minimized.
- Another effect of the large offset, when the wheels hit bump or a pothole a large opposing twisting force would be created quickly which would be relayed back to driver steering wheel in a twitching fashion.



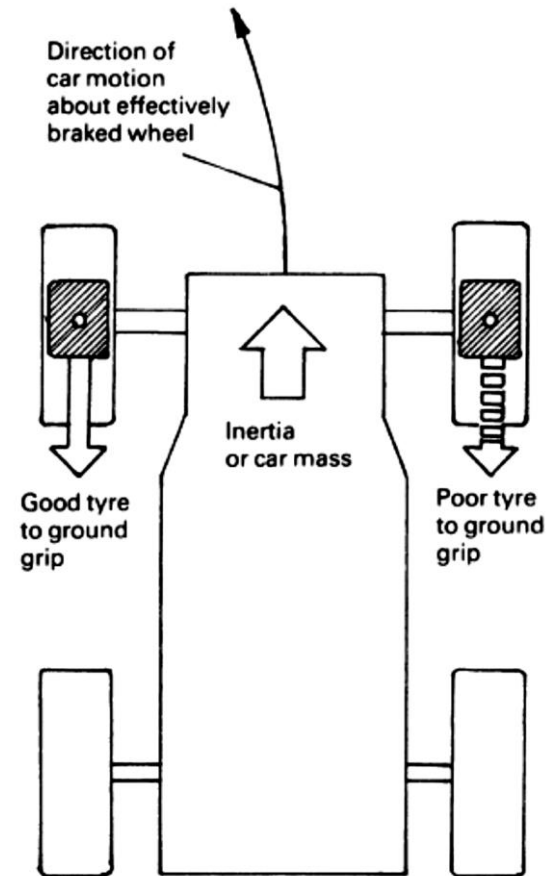


- If the offset of the king pin inclination is on the inside of the tyre contact patch center then it is called as positive scrub radius or positive offset.
- If the offset of the king pin inclination is on the outside of the tyre contact patch center then it is known as the negative scrub radius or negative offset.





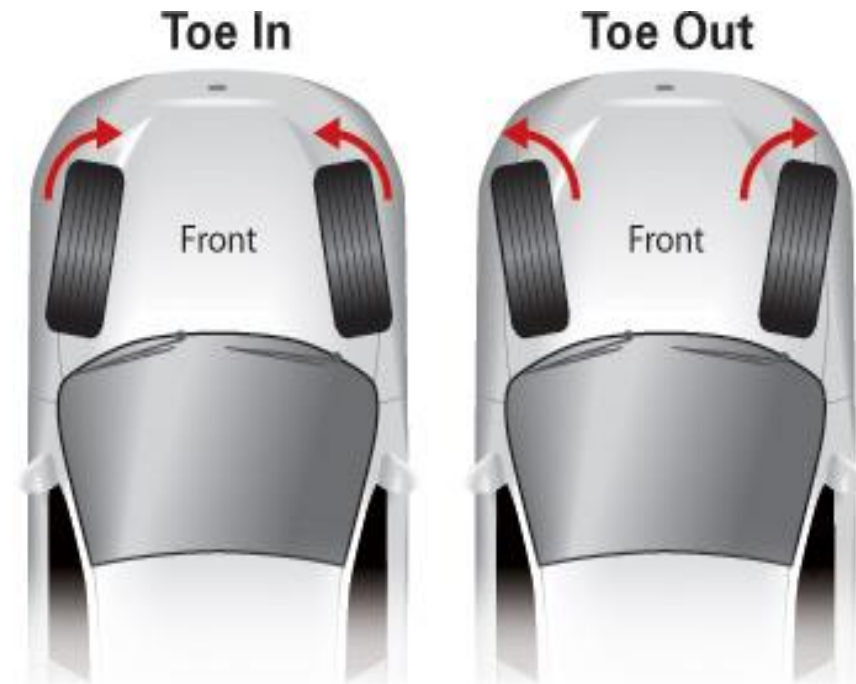
- When one of the front wheel slips during a brake application the inertia of the moving mass will tend to swing the vehicle about the effectively braked wheel which brings the retardation because there is very little opposing resistance from the wheel on opposite side.

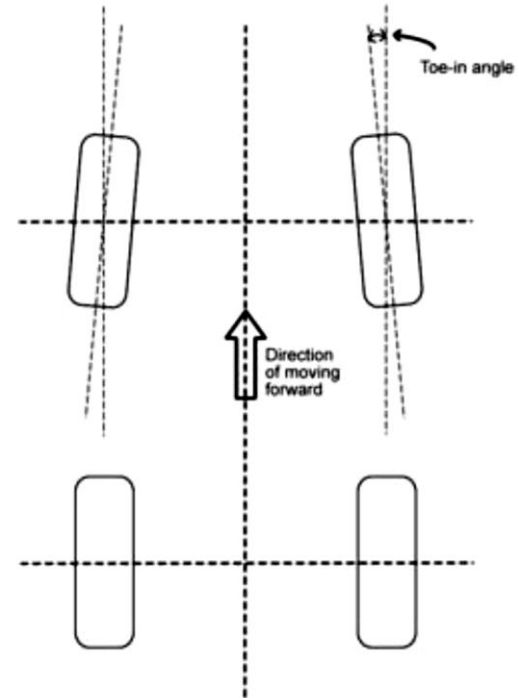
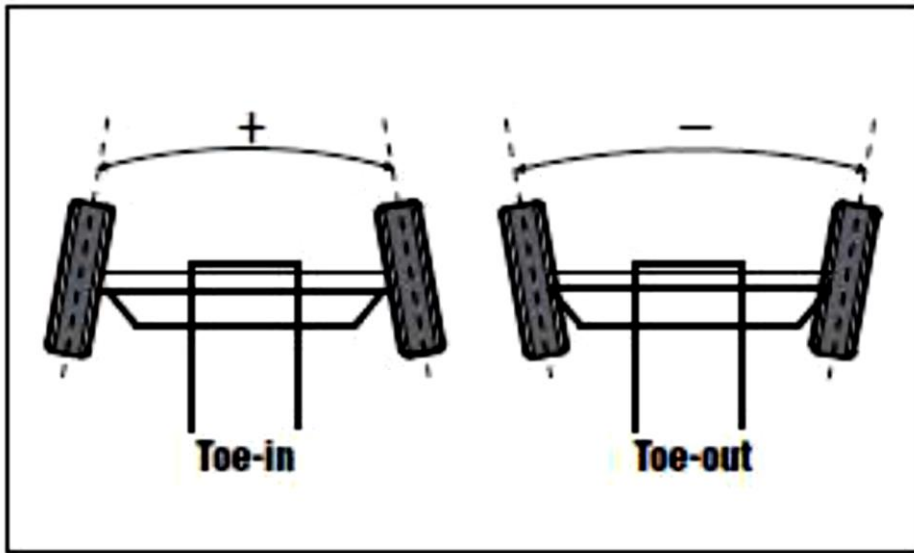




## ❖ Toe- In & Toe- Out

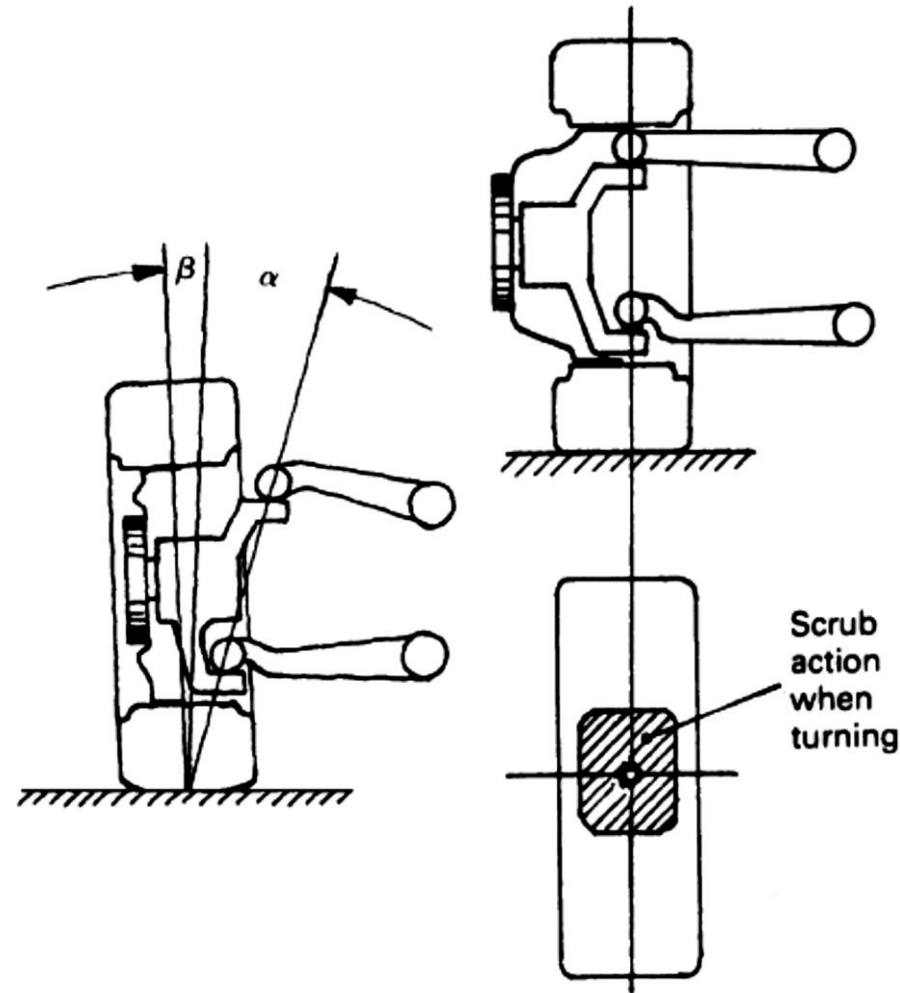
- In automotive engineering, toe also known as tracking.
- Positive toe, or **toe in**, is the front of the wheel pointing in towards the centerline of the vehicle
- Negative toe, or **toe out**, is the front of the wheel pointing away from the centerline of the vehicle.
- The amount of toe in varies from 0-6 mm on different vehicles.
- 2 to 4 mm Maruti 800.





## ❖ Center Point Steering:

The combination of both camber and KPI is known as included angle and the intersection of these axes at one point at a ground level classifies this geometry as Center point steering.







## ❖ Reversible, Irreversible and Semi-reversible Steering

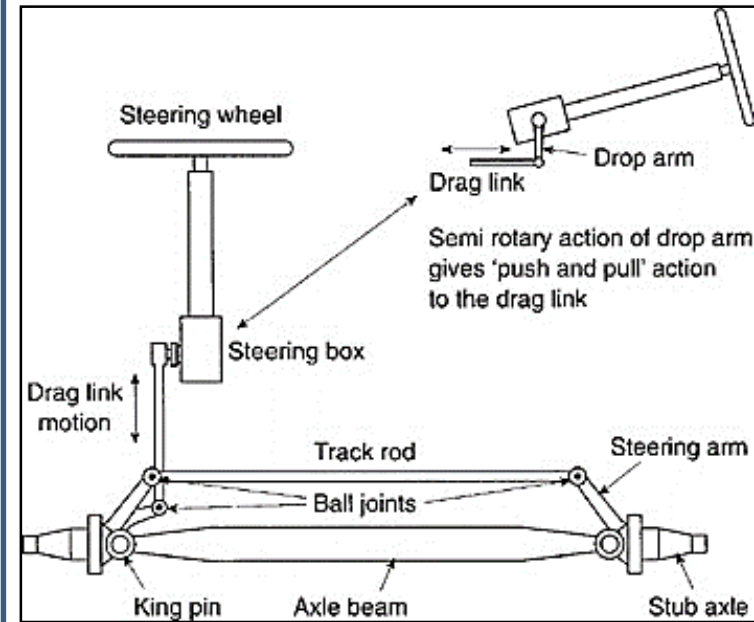
- When an effort (i/p) is applied on the steering wheel which causes the road wheels to swivel(o/p).
- If this action is reversed by swiveling the road wheels (i/p), the steering wheel can be turned(o/p) then the system is known as *reversible steering*.
- In an *irreversible steering* it is not possible to turn the steering wheel by swiveling the road wheels.
- A compromise made between the short coming of the two systems results in semi reversible steering



Description	Reversible	Irreversible	Semi irreversible
Transmission of road shocks to steering	Yes, fully	No, nil	no
Control of steering	Difficult	Less difficult	Better
Fatigue to driver	Greater	Lesser	Intermediate
Feeling of road conditions	Yes, fully	No, nil	Yes
Load on joints	Less	More	Fair

## ❖ Steering System Layout:

- Steering System consists of Steering Wheel, Steering Gearbox, Drag link, Drop Arm, Track Rod, Steering Arm etc.
- The angular movement of the Steering wheel is converted into reciprocating motion of the drag link by means of a steering gearbox and drop arm.
- The drag link converts the reciprocating motion into angular movement of wheels.



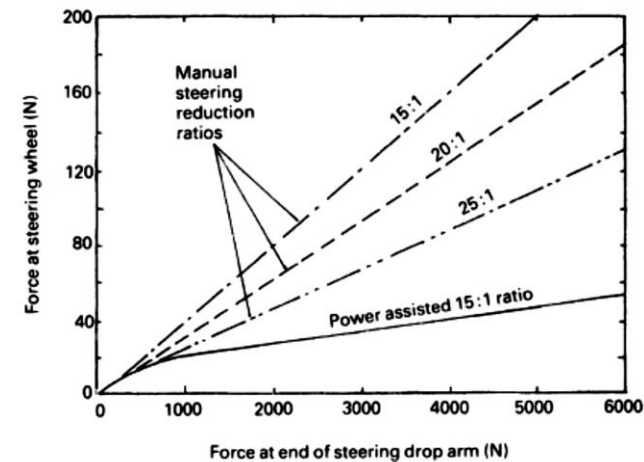


## ❖ Steering Gear:

- Generally, steering gear has mainly two functions: it produces a gear reduction between the input steering wheel and the output drop arm (pitman arm), it redirects the input to output axis of rotation through the right angle.
- Simply, the steering gear is a device for converting the rotary motion of the steering wheel into straight line motion of the linkage with a mechanical advantage.
- If the steering wheel is connected directly to the steering linkage it would require a great effort to move the front wheels.
- Therefore, to assist the driver, a reduction system is used having a steering ratio (*the ratio between the turn of the steering wheel in degrees or handlebars and the turn of the wheels in degrees*) between 12:1 to 28:1 the actual value depending upon the type and weight of the vehicle.

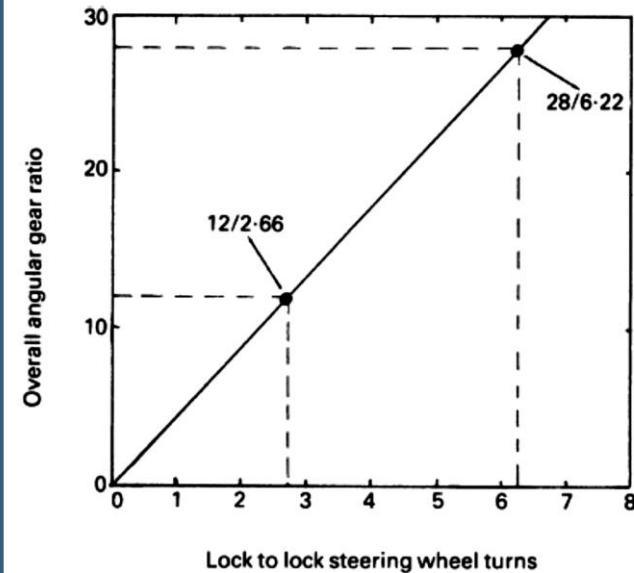


- A higher steering ratio means that you have to turn the steering wheel more, to get the wheels turning, but it will be easier to turn the steering wheel.
- A lower steering ratio means that you have to turn the steering wheel less, to get the wheels turning, but it will be harder to turn the steering wheel.
- Larger and heavier vehicles like trucks will often have a higher steering ratio, which will make the steering wheel easier to turn.
- In normal and lighter cars, the wheels are easier to turn, so the steering ratio doesn't have to be as high.
- In race cars the ratio becomes really low, because you want the vehicle to respond a lot quicker than in normal cars.





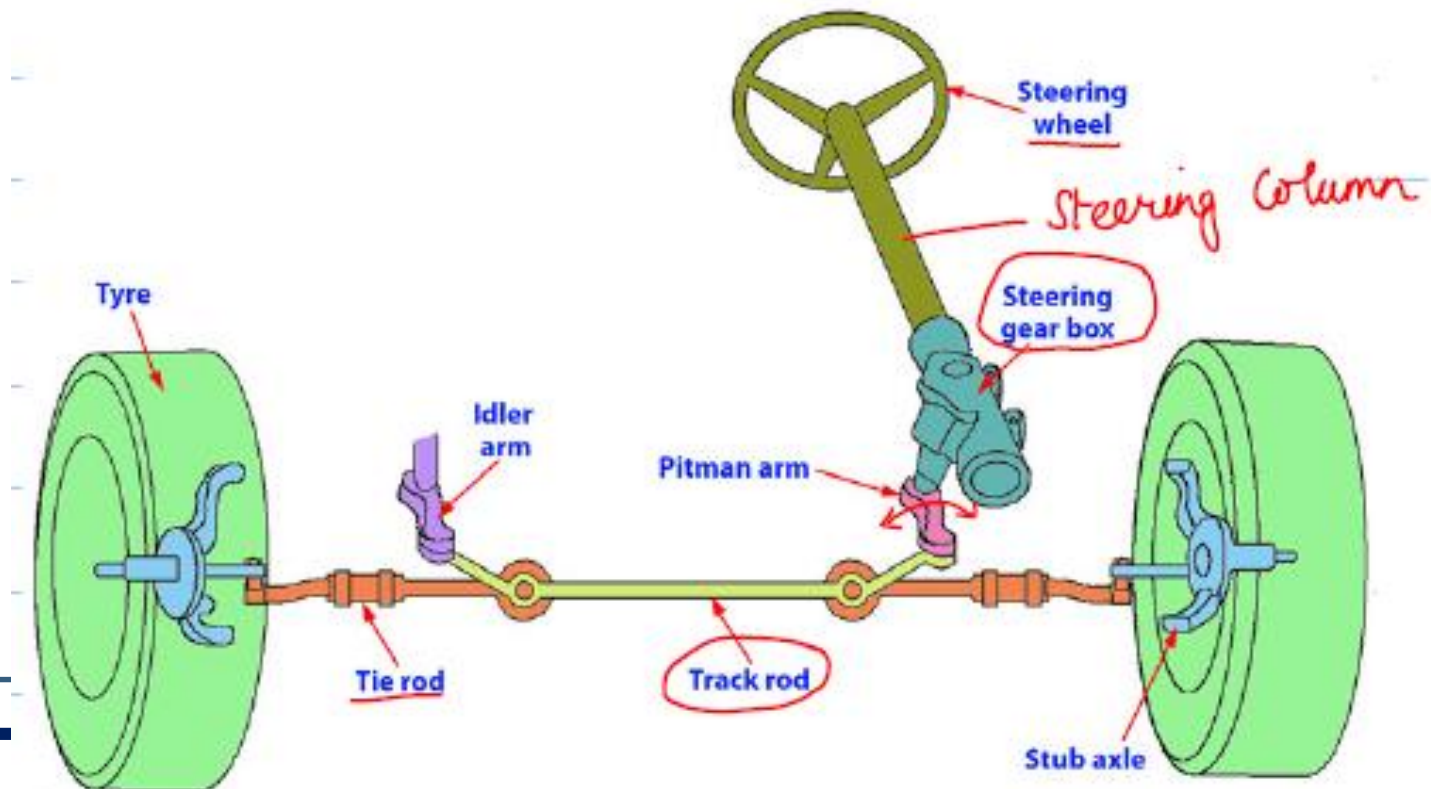
- Generally, the stub axles must be capable of twisting through a maximum steering angle of  $40^\circ$  either side of straight ahead position.
- Therefore lock to lock drop arm angular displacement amounts to  $80^\circ$
- With 12:1 Gear reduction steering wheel turns  
 $= (80 \times 12) / 360 = 2.66$  turns
- With 28:1 Gear reduction steering wheel turns  
 $= (80 \times 28) / 360 = 6.22$  turns





## ❖ Types:

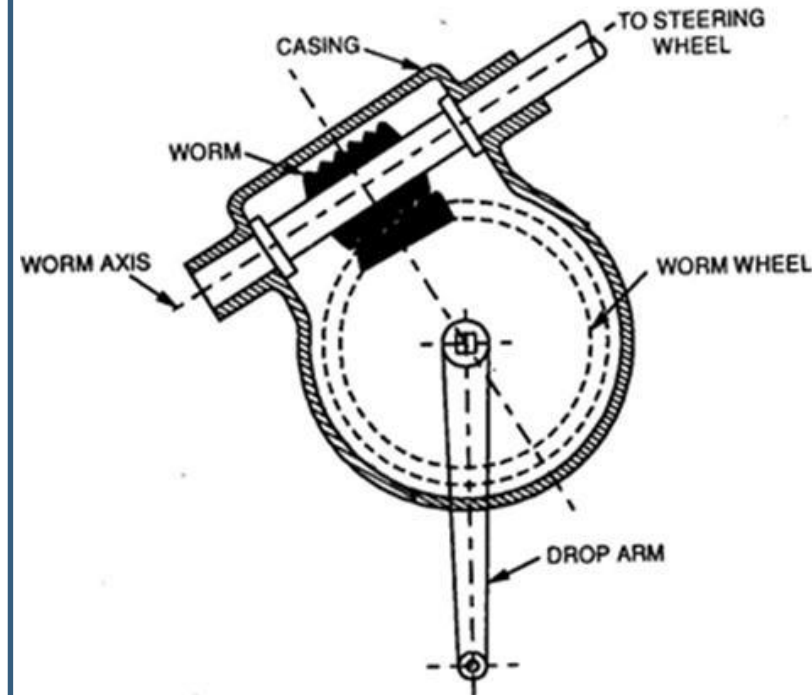
1. Worm and wheel steering gear
2. Worm and sector steering gear
3. Cam and lever / peg steering gear
4. Recirculating ball steering gear
5. Rack and pinion steering gear.





## 1. Worm and Worm Wheel Steering Gear:

- The system consists of worm wheel which is carried in bearings in a cast iron case.
- The case is made in halves. The outer end of the worm wheel is fixed to a drop arm which is having ball end to connect the side rod.
- The side rod is connected to the steering arm which is fixed to the stub axles.
- The worm which is keyed on to a steering shaft have a mesh with the worm wheel.
- The steering wheel is mounted at the upper end of the steering shaft.
- When driver rotates the steering wheel then drop arm moves either backward or forward direction. This motion results in motion of the stub axles.

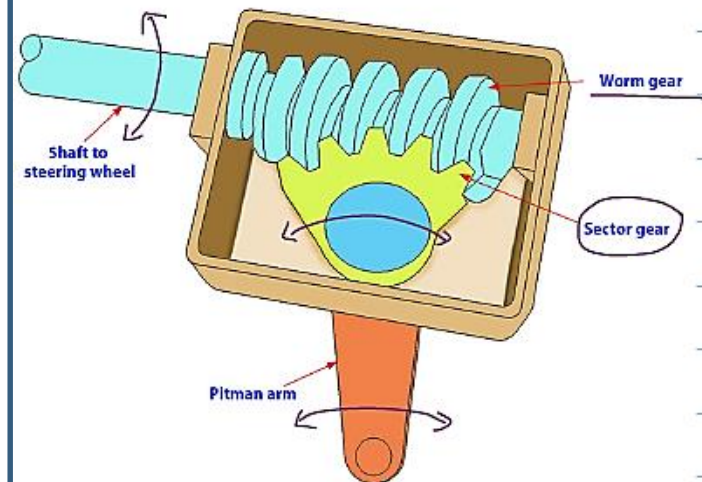
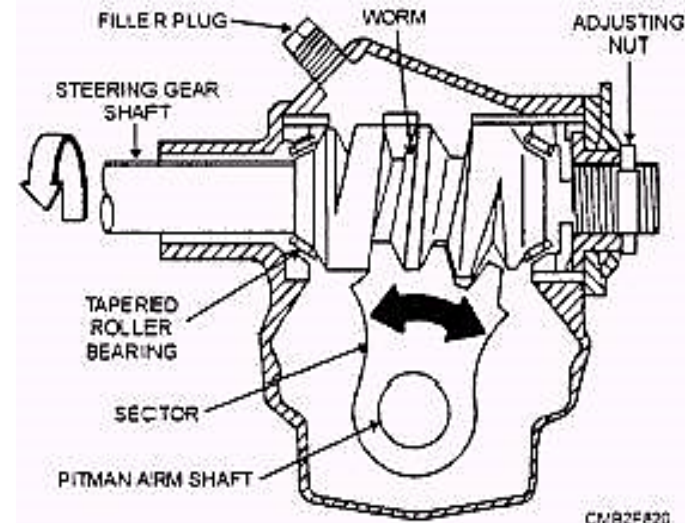


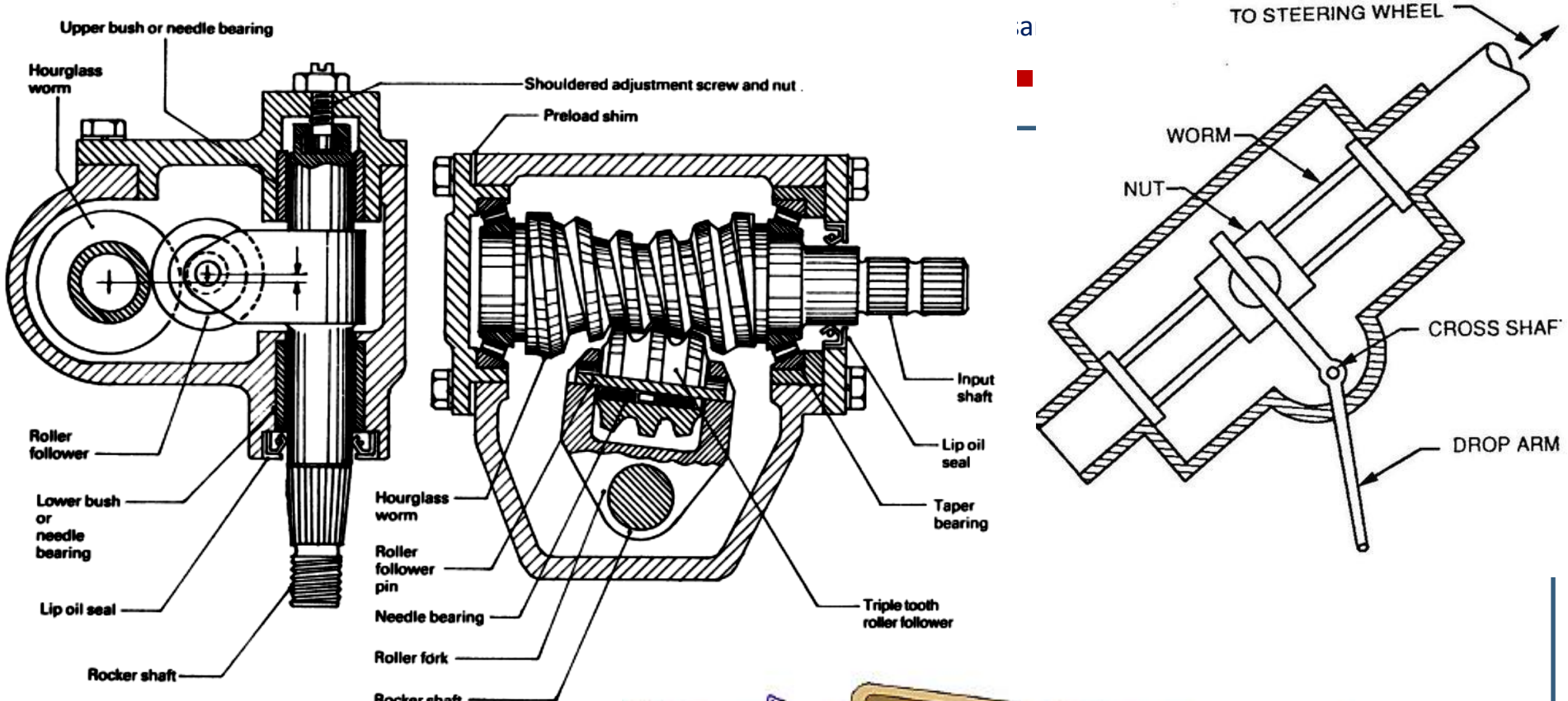




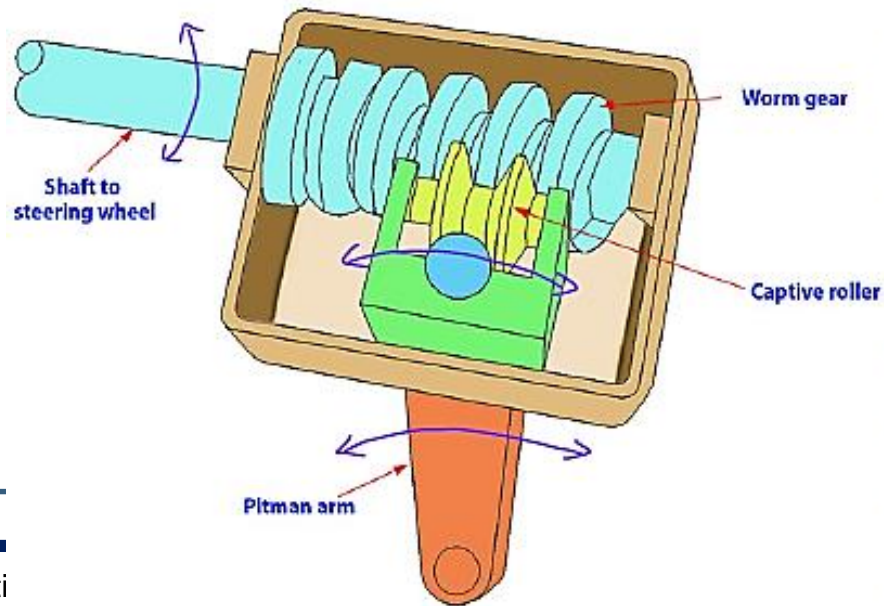
## 2. Worm and Sector Steering Gear

- In this type of steering box, the end of the shaft from the steering wheel has a worm gear attached to it.
- It meshes directly with a sector gear (so called because it's a section of a full gear wheel).
- When the steering wheel is turned, the shaft turns the worm gear, and the sector gear pivots around its axis as its teeth are moved along the worm gear.
- The sector gear is mounted on the cross shaft which passes through the steering box and out the bottom where it is splined, and the pitman arm is attached to the splines.
- When the sector gear turns, it turns the cross shaft, which turns the pitman arm, giving the output motion that is fed into the mechanical linkage on the track rod.
- The box itself is sealed and filled with grease. In actual case, the worm wheel is not essential as it is having only partial rotation.
- Hence in this type only a sector of wheel is used instead of worm wheel.





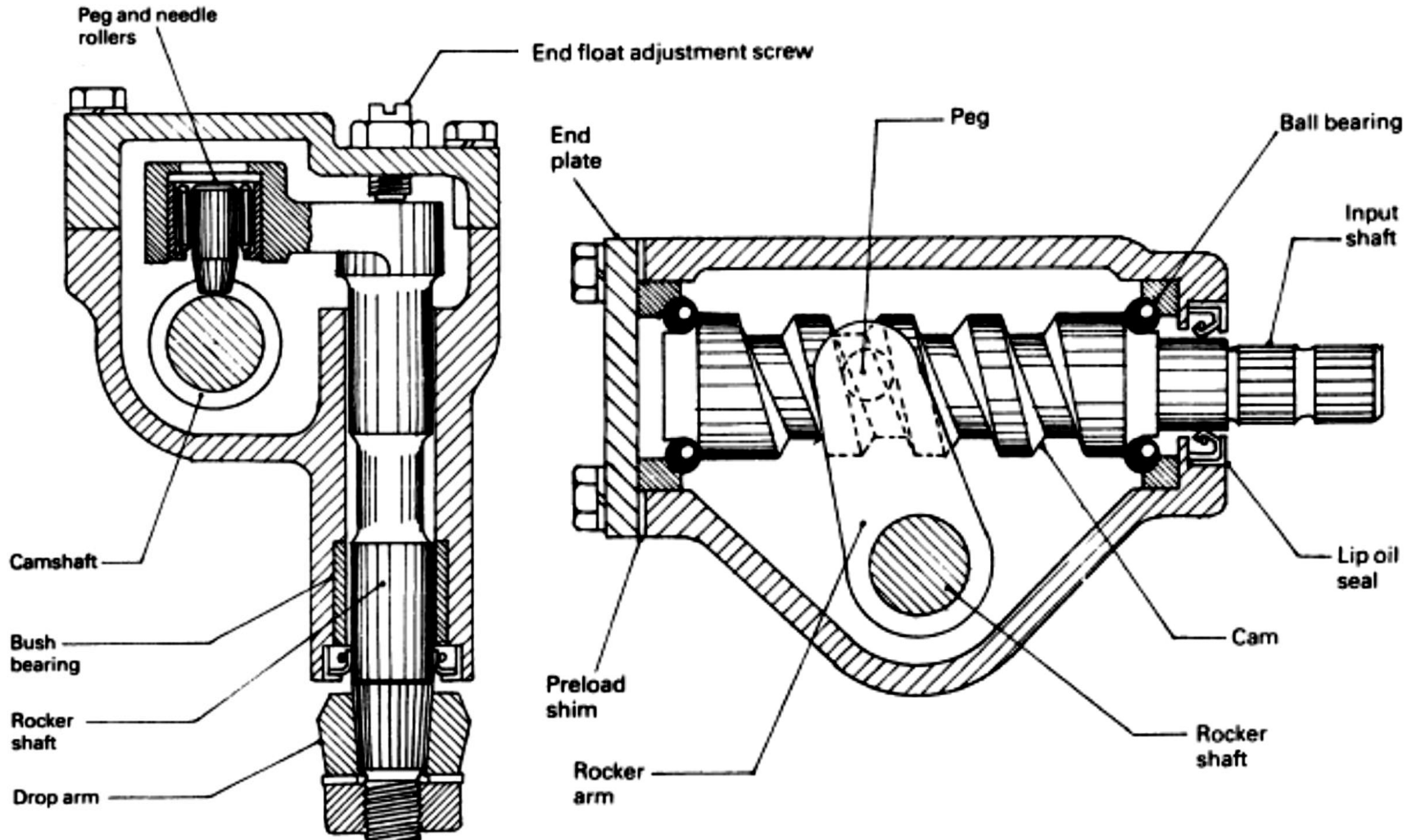
0.7 Worm and roller type steering gearbox





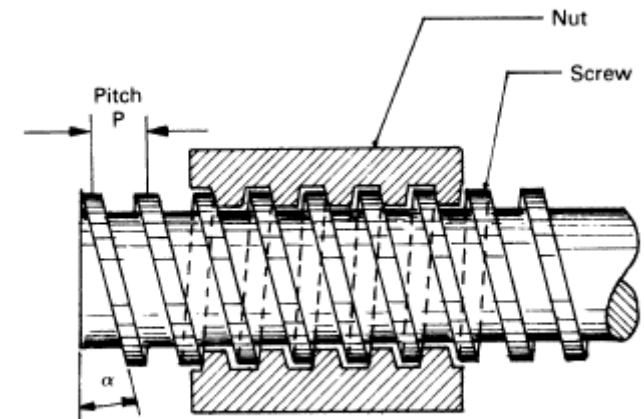
### 3. Cam and Peg/Lever Steering Gear:

- Here a helical groove is formed at the bottom end of the steering wheel shaft.
- The helical groove engages the projected pin of the drop arm spindle lever.
- The drop-arm is made rigid with the lever/peg by a splined spindle. The to and fro motion is obtained at the drop-arm when the steering wheel shaft is turned. This motion results the turning of the stub axles.
- The end play of the steering wheel shaft can be adjusted by putting a suitable washer at the lock nut.
- The meshing of the projected pin in helical groove is also adjusted by a screw provided at the end of the lever spindle. In the recent models, the projected pin is made in the form of a roller.
- The projected pin may be one or two in number, accordingly they are referred as cam and single lever or double lever steering gear mechanism



## ❖ Screw and Nut Steering Gear

- The screw and nut steering gear is the foundation for all types other steering gear reduction mechanisms.
- A screw and nut combination mechanism which increases both force and movement ratios.
- A small input effort applied to the end of perpendicular lever fixed to the screw is capable of moving much larger load axially along the screw provided that nut is prevented from rotating.



**Fig. 9.2** Screw and nut friction steering gear mechanism

## 4. Reciprocating Ball type Steering Gear:

- It consists of a worm at the end of steering rod. A nut is mounted on the worm with two sets of balls in the grooves of the worm, in between the nut and, the worm.
- The balls reduce the friction during the movement of the nut on the worm. The nut has a number of teeth on outside, which mesh with the teeth on a worm wheel sector, on which is further mounted the drop arm.
- When the steering wheel is turned, the balls in the worm roll in the grooves and cause the nut to travel along the length of the worm.
- The balls, which are in 2 sets, are recirculated through the guides. The movement of the nut causes the wheel sector to turn at an angle and actuate the link rod through the drop arm, resulting in the desired steering of the wheels.
- The end play of the worm can be adjusted by means of the adjuster nut provided.
- To compensate for the wear of the teeth on the nut and the worm, the two have to be brought nearer bodily.
- To achieve this, the teeth on the nut are made tapered in the plane perpendicular to the plane of Figure.

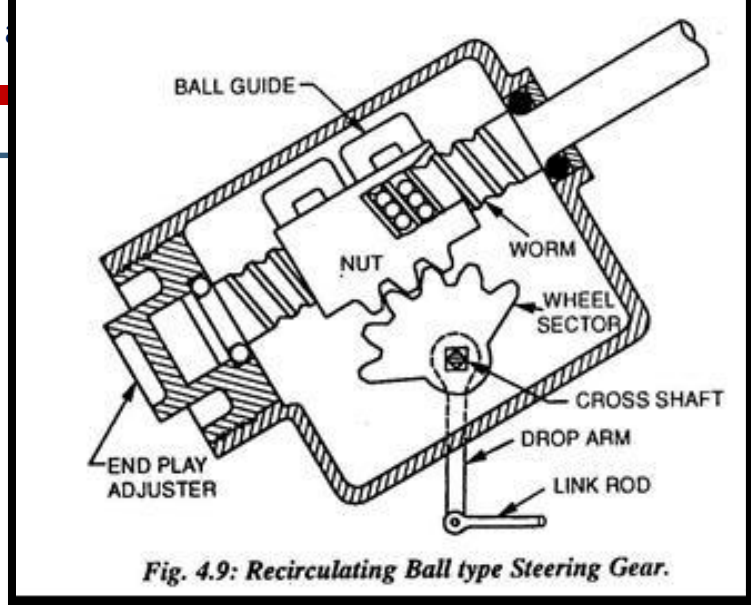
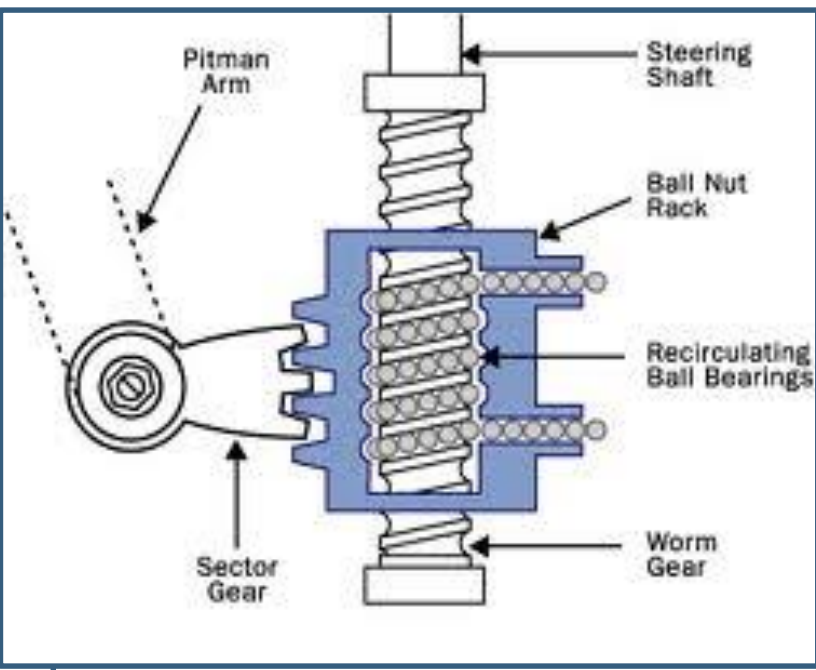


Fig. 4.9: Recirculating Ball type Steering Gear.

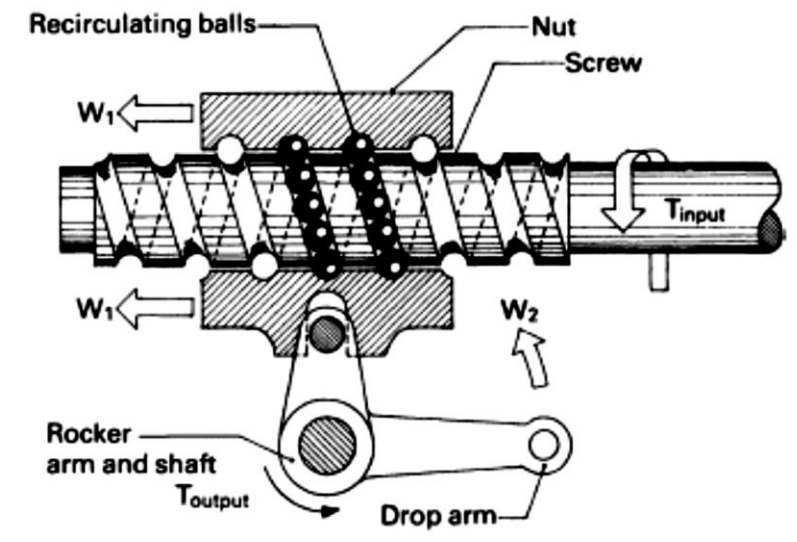
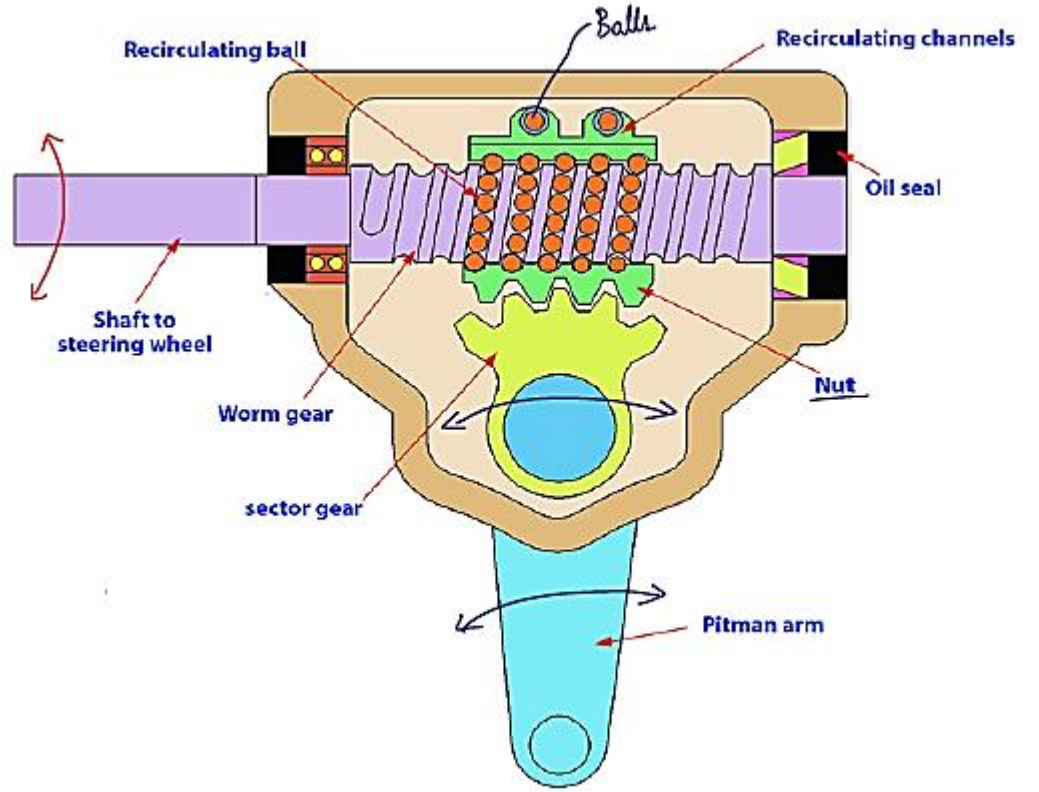


Fig. 9.4 Screw and nut recirculating ball low friction gear mechanism



## 5. Rack and Pinion Steering Gear:

- This type of steering gear is used on light vehicles like cars and in power assist steering.
- It is simple light and responsive.
- It occupies very small space and uses lesser number of linkage components compared to the worm and wheel type of gear.
- The rotary motion of the steering wheel is transmitted to the pinion of the steering gear through universal joints
- The pinion is in mesh with a rack.
- The circular motion of the pinion is transferred into the linear rack movement, which is further relayed through the ball joints and tie rods to the stub axles for the wheels to be steered.

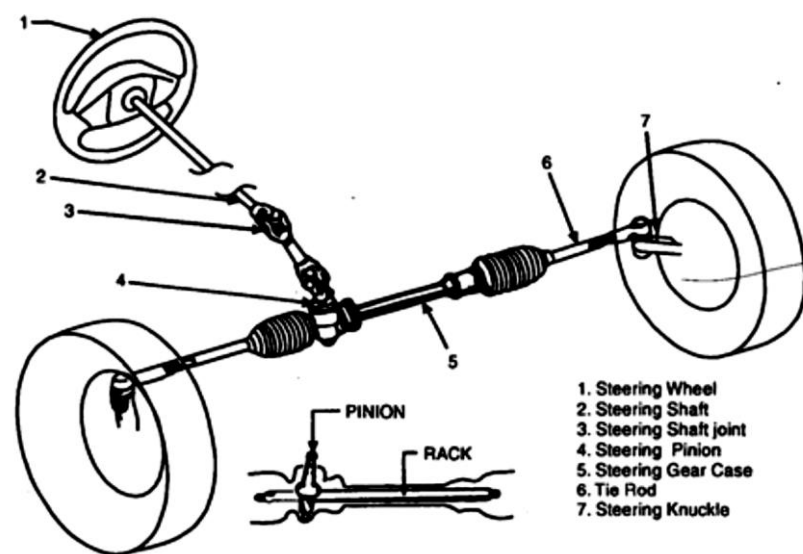


Fig. 4.10: Rack and Pinion Steering System (Cortesy- Maruti Udyog Ltd. India).

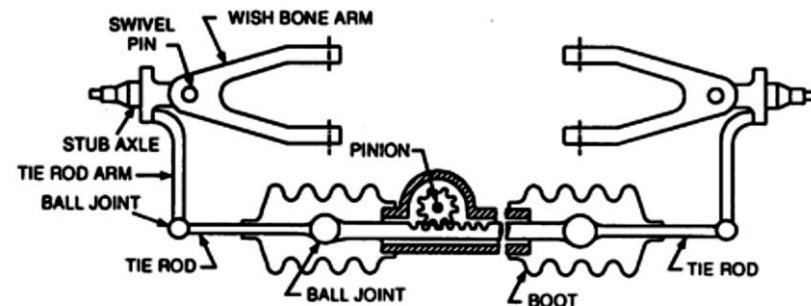
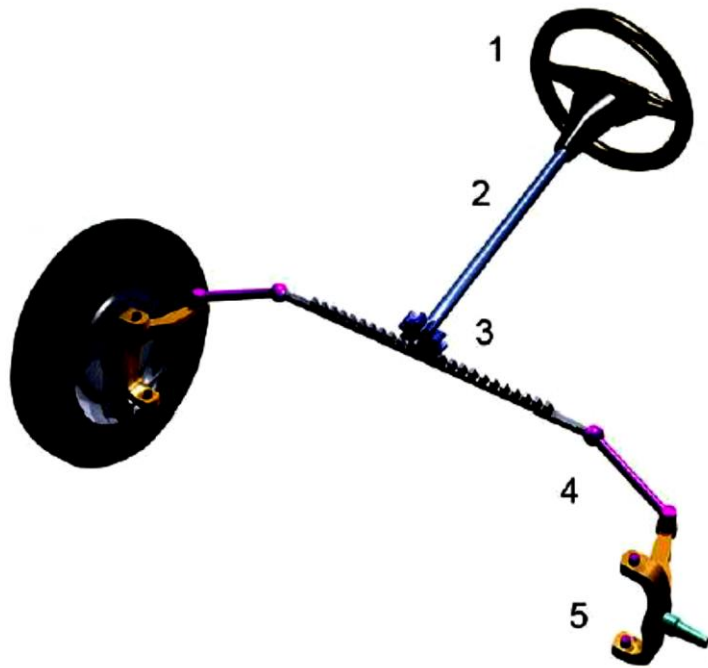
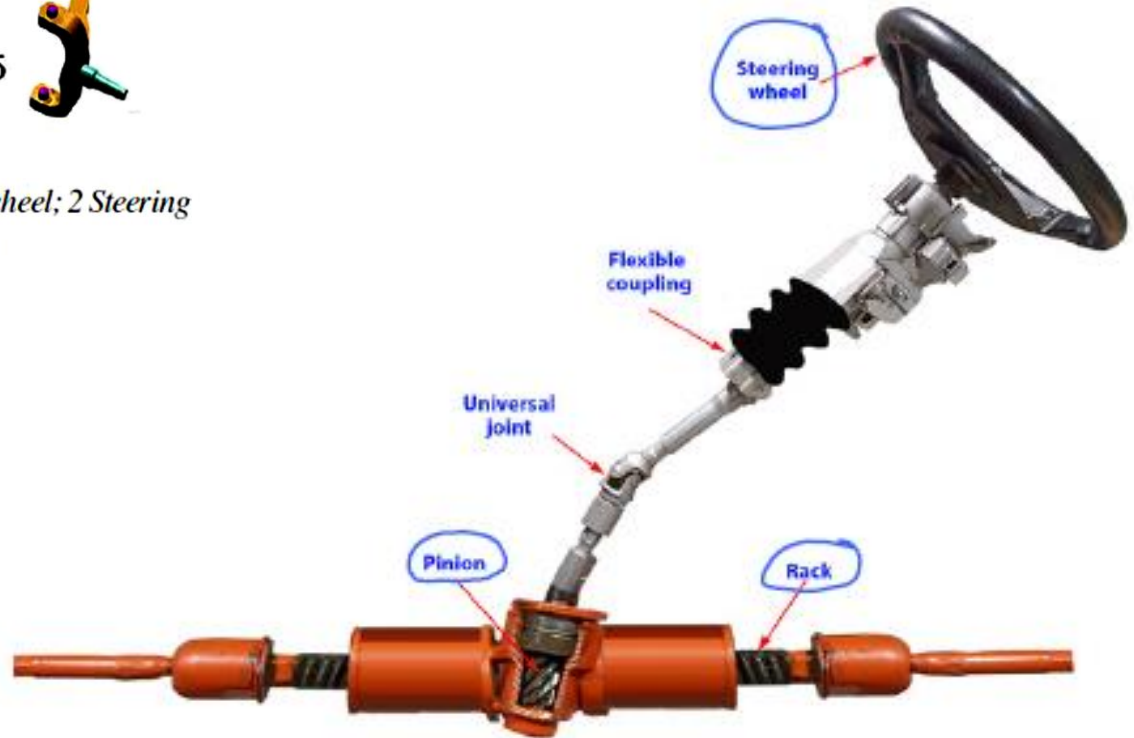


Fig. 4.11. Rack and Pinion Steering Gear.





*Rack and pinion steering mechanism: 1 Steering wheel; 2 Steering column; 3 Rack and pinion; 4 Tie rod; 5 Kingpin*





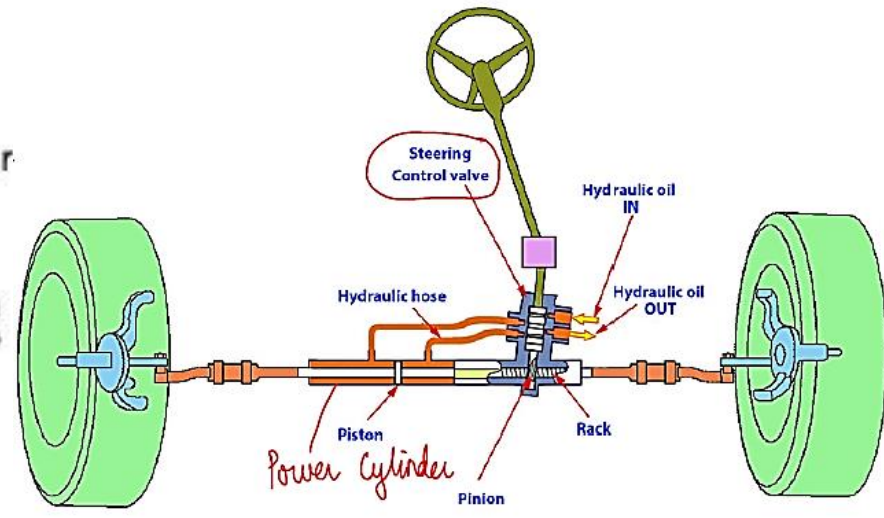
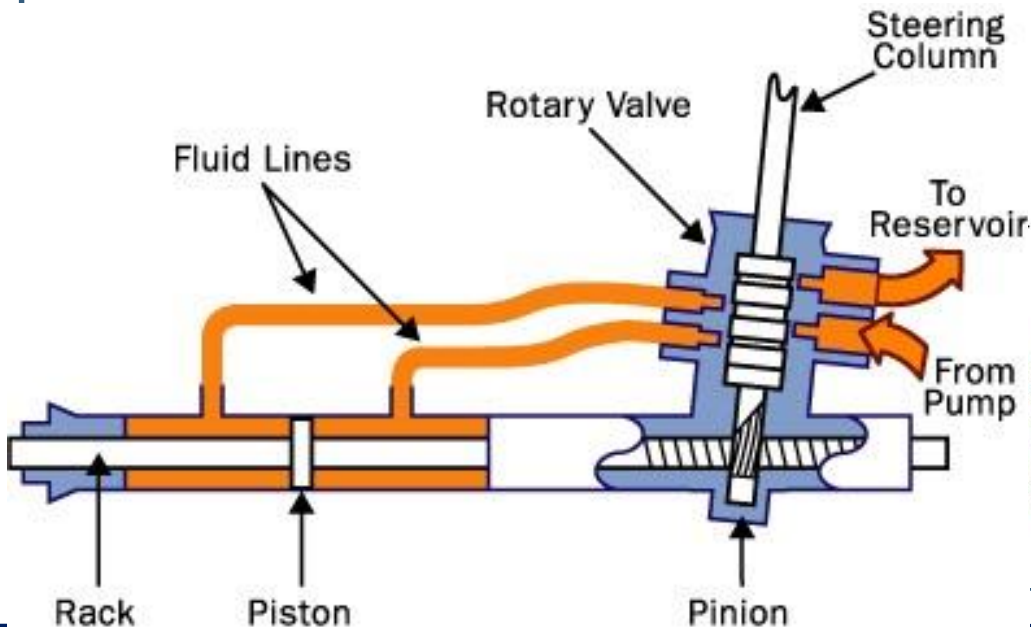
## ❖ Power Steering:

- The main objective of power steering is to reduce the driver's effort in steering.
- This system may employ electrical devices and hydraulic pressure.
- Power steering is basically power assisted steering in which an arrangement to boost the steering wheel turning is provided.



## Hydraulic Power Assisted Steering Gear:

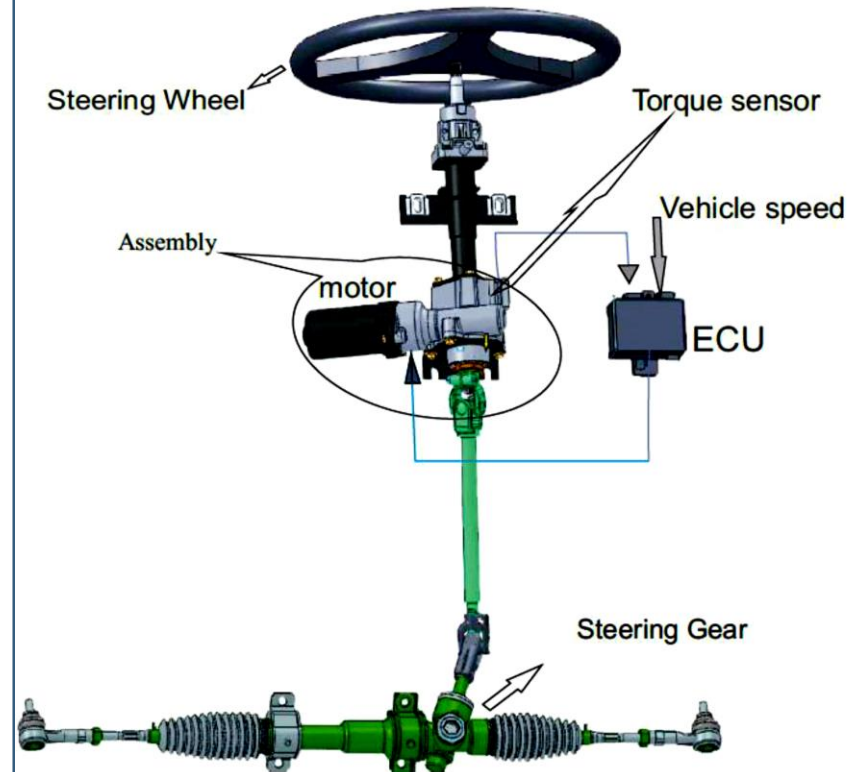
- When the rack-and-pinion is in a power-steering system, the rack has a slightly different design.
- Part of the rack contains a cylinder with a piston in the middle.
- The piston is connected to the rack. There are two fluid ports, one on either side of the piston.
- Supplying higher-pressure fluid to one side of the piston forces the piston to move which in turn moves the rack so providing power assist.





## ❖ Electric Power Assist Steering Gear:

- It uses an electric motor to reduce effort by providing steering assist to the driver of a vehicle.
- Sensors detect the motion and torque of the steering column, and a computer module applies assistive torque via an electric motor coupled directly to either the steering gear or steering column.
- This allows varying amounts of assistance to be applied depending on driving conditions.
- The system allows engineers to tailor steering-gear response to variable-rate and variable-damping suspension systems achieving an ideal blend of ride, handling, and steering for each vehicle.
- In the event of component failure, a mechanical linkage such as a rack and pinion serves as a back-up in a manner similar to that of hydraulic systems.







## ❖ **Electro-hydraulic Power Assist Steering Gear:**

- Electro-hydraulic power steering systems, sometimes abbreviated EHPS, and also sometimes called "hybrid" systems, use the same hydraulic assist technology as standard systems, but the hydraulic pressure is provided by a pump driven by an electric motor instead of being belt-driven by the engine.
- By providing power assist via hydraulic pressure, this system delivers a naturally smooth steering feel and, thanks to the flexibility of control allowed by electric power, offers more precise steering power characteristics. It also improves fuel economy since the electric powered pump operates only when steering assist is needed

